

EN



Non
bestemmiare
adopera USAG
utensili professionali

100
Anni
1926

**SUPER
OFFER
2026**

66/2026
Valid till 31/03/2027



THE RED HOUSE



**SOMETHING IS
ABOUT TO HAPPEN...**

SCAN THE QR



STAY TUNED



The monograph

USAG celebrates 100 years of history, passion, and innovation.

To mark this anniversary, we decided to do something special: **an original monograph, unconventional**, designed and created especially for you. Not just a simple commemorative story, but a project capable of surprising you and offering you an experience unlike any other.

Are you curious? **Look for the USAG monograph**: you might discover something unexpected, containing much more than you imagine!



Deed of Incorporation of the Company

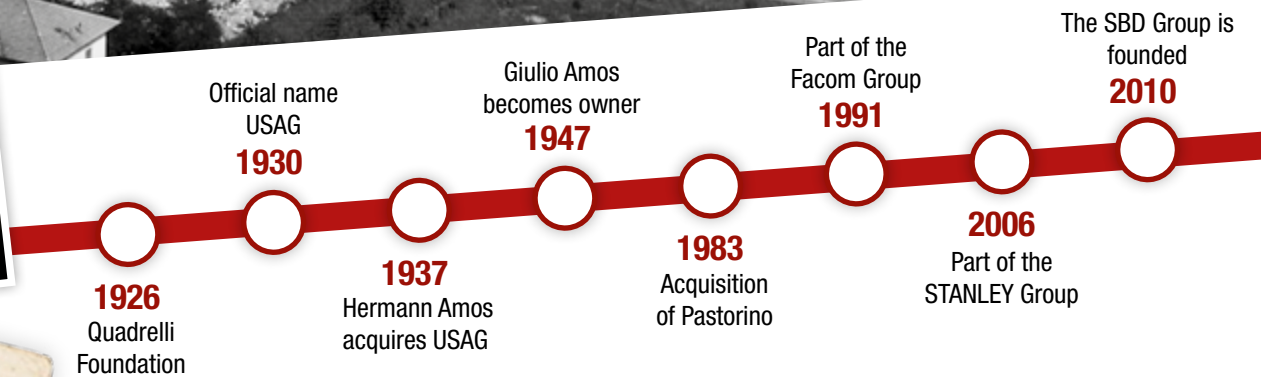

The story of our 100 years

The company was founded in Gemonio on April 1, 1926, through the initiative of Anselmo Quadrelli and Teresita Luraschi. From the very beginning, the production of hand tools came to life in the "Ca' Rossa," on a piece of land provided by Quadrelli himself.

In 1930, with the departure of the founder, the company took the name "Utensileria Società Anonima Gemonio" (USAG). The year 1937 marked a decisive turning point: the company was acquired by Hermann Amos, an entrepreneur of German origin born in Aquileia and residing in Milan, who began expanding the plant.

From 1947 to 1991, leadership passed to his son Giulio Amos, who played a key role in USAG's growth during the Italian economic boom, thanks to tools of great quality and reliability.

In 1991, USAG entered into the French group Facom; in 2006, it became part of the American group STANLEY and, since 2010, has been part of Stanley Black & Decker, a structure that still exists and operates in the market today.

Within this multinational context, the company has managed to maintain its identity and autonomy, strengthening itself through productive, technological, commercial, and marketing synergies.

DISCOVER THE NEWS 2026

Index by categories



New

XGRIP Page 6



ICONIC PRODUCT

Page 46



New

JUST Page 92



New

Roller cabinets
Page 18



New

Workshop furniture
Page 28



New

Workbenches
Page 32



New

Other roller cabinet
Page 36



Portable containers
Page 38



Assortments
Page 42



New

Maintenance suitcase
Page 41



Screwdrivers
Page 48



Hexagon keys and bits
Page 50



Wrenches
Page 52



New

Pliers and cutting nippers
Page 54



Ratchets and sockets
Page 60



New

Torque Control
Page 62



Lighting
Page 65



Electrotechnics
Page 66



New

Rivet pliers
Page 68



New

Pullers
Page 72



Automotive
Page 76



Air tools and accessories
Page 84



New

Comfort and protection
Page 91

ALL THE ADVANTAGES OF X-Grip TECHNOLOGY



DAMAGED SCREWS

X-Grip allows you to work effectively on both new and heavily damaged screws: the tool will not lose its grip on the screw, enabling you to continue with your work.



TORQUE TRANSMISSION

The grip that the X-Grip profile exerts on the head of a new screw allows for the transmission of a higher tightening torque compared to standard profiles. This is a real advantage when dealing with a new screw tightened with high torque, making it difficult to loosen.



PREVENTS DAMAGE

X-Grip profiles are designed to prevent damage to the profiles of new screws. By using X-Grip tools, new screws will have a longer lifespan.

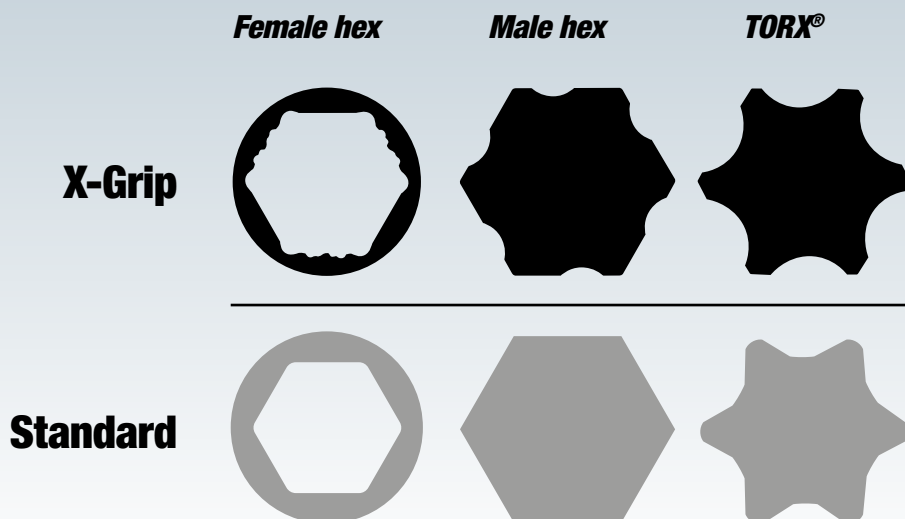



YouTube

COMBINATION WRENCH 285 X

INCLINED OPEN END

angled at 15° as regards to wrench axis.

DOUBLE T SECTION

Excellent resistance to flexion.

SPECIAL RING SHAPE

Ideal for operations on nuts difficult to reach.

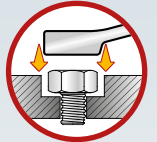

+30% LONGER THAN A STANDARD COMBINATION WRENCH 285

It allows to apply a torque of 30% higher than the standard key.



SPECIAL X-Grip PROFILE

Effective even on heavily damaged screws. On new screws, it transmits greater torque and preserves the screw profile's lifespan.



8
PIECES

8÷19 mm



285 X/B8
U02850950

Set of 8 combination wrenches with special profiles

- 285 X/8-10-11-12-13-14-17-19 mm.
- Supplied in a high strength fabric roll-up bag.

12
PIECES

8÷19 mm



285 X/B12
U02850951

Set of 12 combination wrenches with special profiles

- 285 X/8-9-10-11-12-13-14-15-16-17-18-19 mm.
- Supplied in a high strength fabric roll-up bag.

8
PIECES

8÷19 mm



New

285 X/DS8
U02850954

Set of 8 combination wrenches with special profiles

- 285 X/8-10-13-14-15-16-17-19 mm.
- Supplied with plastic holder

14
PIECES

6÷19 mm



New

285 X/DS14
U02850955

Set of 14 combination wrenches with special profiles

- 285 X/6-7-8-9-10-11-12-13-14-15-16-17-18-19 mm.
- Supplied with plastic holder

SOCKETS 235 X AND 235 XL



YouTube

**SPECIAL CHROME
VANADIUM STEEL**
Chrome plated finish.



SPECIAL X-Grip PROFILE

Effective even on heavily damaged screws. On new screws, it transmits greater torque and preserves the screw profile's lifespan.

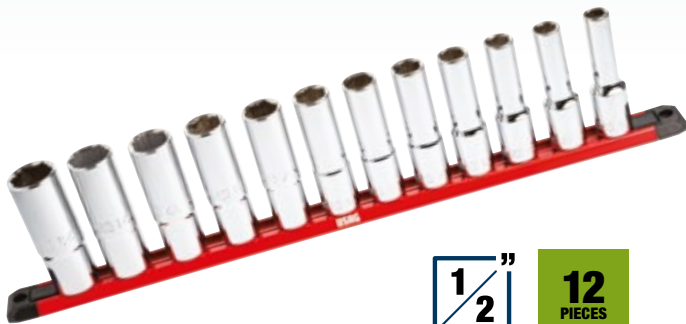

1/2"
12
PIECES

235 1/2" XL/SE12
U02354101

Set of 12 hexagonal sockets with special profile

10-11-12-13-14-
15-16-17-18-19-
21-22 mm

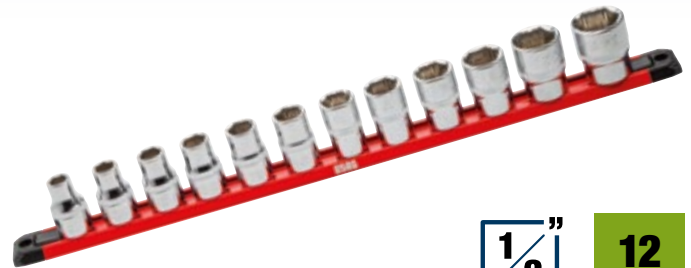

1/2"
12
PIECES

235 1/2" X/SE12
U02350501

Set of 12 hexagonal sockets with special profile

10-11-12-13-14-
15-16-17-18-19-
22-24 mm



1/4"
10
PIECES

235 1/4" X/SE10
U02350500

Set of 10 hexagonal sockets with special profile

5,5-6-7-8-9-10-
11-12-13-14 mm

MAGNETIC LOCKING SOCKET HOLDER 559 A

- Magnetic base protected by a rubber layer: not damage the surface
- 360° adjustable clips, to quickly identify the socket size



SOCKETS 234 X AND 234 MX FOR SCREWS WITH RECESSED HEXAGONS.

**SPECIAL CHROME
VANADIUM STEEL**
Chrome plated finish.



**SPECIAL CHROME
VANADIUM STEEL**
Chrome plated finish.

SPECIAL X-Grip PROFILE

*Effective even on
heavily damaged screws.
On new screws, it
transmits greater torque
and preserves the screw
profile's lifespan.*

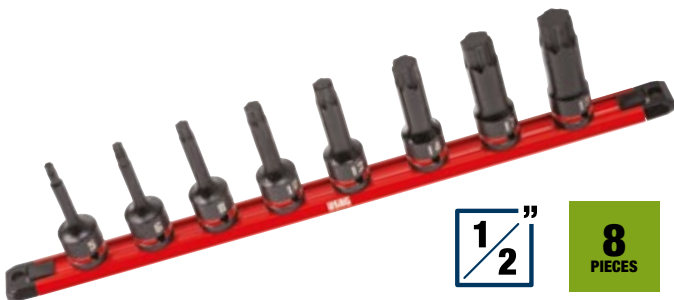
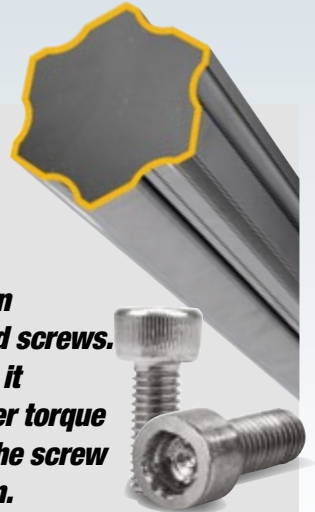

1/2"
8
PIECES



234 1/2"MX/SE8 U02340850

Set of 8 impact socket bits with special X-Grip hex profile for hex socket screws

5-6-8-10-12-
14-17-19 mm

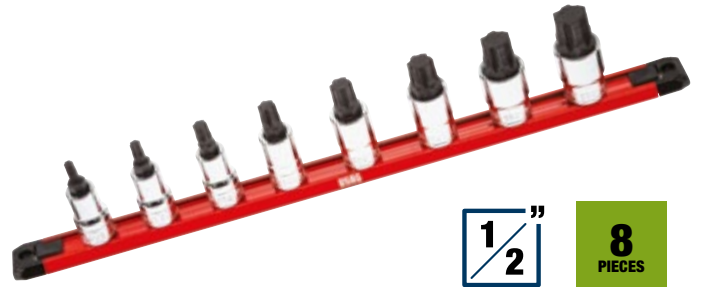

1/2"
8
PIECES



234 1/2"X/SE8 U02342150

Set of 8 socket bits with special X-Grip hex profile for hex socket screws

5-6-8-10-12-
14-17-19 mm

**THE
EFFECTIVENESS
OF X-GRIP.
THE POWER
OF IMPACTS.**



**SOCKETS FOR
RATCHET WITH
INTEGRATED BIT.**



SPECIAL X-Grip PROFILE

Effective even on heavily damaged screws. On new screws, it transmits greater torque and preserves the screw profile's lifespan.



6
PIECES



YouTube

2,5-3-4-5-
6-8 mm

280 HX/SE6

U02802460

Set of 6 angled hexagon keys with special profiles and bimaterial handgrip

- 280 HX/2,5-3-4-5-6-8 mm.
- Ergonomic bimaterial handgrip with anti-slip coating
- Design studied for a safe grip during operations
- Highly alloyed special steel
- Zinc phosphate plated for high corrosion resistance



9
PIECES



YouTube

1,5-2-2,5-3-4-5-
6-8-10 mm

280 X/S9

U02800485

Set of 9 angled hexagon keys with special profiles

- 280 X/1,5-2-2,5-3-4-5-6-8-10 mm.
- It allows you to work on damaged screws even at an angle of 25°
- Highly alloyed special steel
- Zinc phosphate plated for high corrosion resistance
- Supplied with plastic holder



9
PIECES



YouTube

2-2,5-3-4-5-
6-7-8 mm



1/4" Bit-holding socket

660 X/B9

U06600100



Set of bits with special profile

- Special hexagonal profile X-Grip: perfect grip on new or damaged hexagons recessed, up to 92%
- Special steel with phosphated finish
- Including 1/4-1/4" bit holding socket
- Supplied in a compact fabric pouch

DESCRIPTION	ITEM/SIZE	PCS
Bits with special hexagonal profile	660 X 2-2,5-3-4-5-6-7-8	8
Bit-holding socket	684 1/4	1



SPECIAL X-Grip PROFILE
Effective even on heavily damaged screws. On new screws, it transmits greater torque and preserves the screw profile's lifespan.



New

280 HXTX/SE8
U02802451

Set of 8 male keys with special TORX® X-Grip profile and bi-material handle

- Ergonomic bi-material handle with non-slip coating
- Design engineered for a secure grip during operation
- High-alloy special steel
- Zinc-phosphate finish for high corrosion resistance

8
PIECES

T8-T10-T15-T20-T25-T27-T30-T40



280 HXTX/SE6
U02802450

Set of 6 male keys with special TORX® X-Grip profile and bi-material handle

- Ergonomic bi-material handle with non-slip coating
- Design engineered for a secure grip during operation
- High-alloy special steel
- Zinc-phosphate finish for high corrosion resistance

6
PIECES

T8-T10-T15-T20-T25-T30

T8-T10-T15-T20-T25-T30

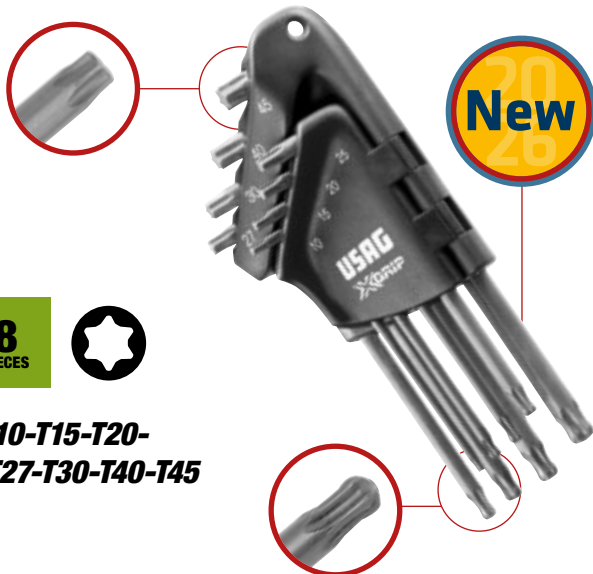

New

280 XTX/S8
U02800080

Set of 8 TORX® keys with special X-Grip profiles

- High-alloy special steel
- Zinc-phosphate finish for high corrosion resistance
- Plastic holder

8
PIECES

T10-T15-T20-T25-T27-T30-T40-T45



28
PIECES

New

Bit-holder 



660 XTE/S28

U06600113

Set of bits with hexagonal and special X-Grip TORX® profiles

- Special steel with phosphated finish
- Supplied with plastic holder



1,5-2-2,5-3-4-5-5,5-6-7-8-9-10 mm



5-6 mm



T6-T7-T8-T9-T10-T15-T20-T25-T27-T30-T40-T45-T47-T50



11
PIECES

New

Bit-holder 



660 X/S11

U06600111

Set of bits with special X-Grip hexagonal profile

- Special steel with phosphated finish
- Supplied with plastic holder



2-2,5-3-4-5-6-7-8-9-10 mm



11
PIECES

New

Bit-holder 



660 XSTX/S11

U06600112

Set of TORX® bits with special X-Grip profile

- Special steel with phosphated finish
- Supplied with plastic holder



T6-T8-T10-T15-T20-T25-T27-T30-T40-T50



QUICK RELEASE SYSTEM

The bit holders stand out for their advanced extraction system, which allows you to quickly and safely remove bits and bit holders with just one hand.

COMBINATION PLIERS 151 X

SPECIAL JAWS FOR DAMAGED SCREWS AND THREADS.

**INDUCTION-HARDENED
CUTTING EDGES**

COMPACT HEAD
For excellent accessibility.

**ERGONOMIC
BIMATERIAL GRIP**



JAWS WITH SPECIAL INTERNAL PROFILE

*Allow a frontal grip on
diameters up to 15 mm.
Effective even with little
residual material to grip.*



151 X
U01510160

Combination pliers with special X-Grip jaws

- Jaws with special inner profile for front gripping of screws or threaded rods up to a diameter of 15 mm
- Also ideal for front gripping of small hexagons
- Effective on flat material as well, thanks to the 4 front contact points
- Side serrated groove for gripping round or hexagonal material
- Cutting edges further induction-hardened
- Compact head for excellent accessibility
- Allow cutting of soft, medium-hard, and hard metal wire
- Open hinge with forged joint
- Ergonomic bi-material handles
- Blackened finish with milled surfaces

**UNIVERSAL MULTI-GRIP
JAWS WITH
INTEGRATED CUTTER**

RANGE OF X-Grip SETS IN CASE

Includes hex bits, Torx bits, and X-Grip sockets.

SPECIAL X-Grip PROFILE

Effective even on heavily damaged screws.

On new screws, it transmits greater torque and preserves the screw profile's lifespan.



23
PIECES



YouTube



Socket-holder



609 1/4" SKX U06090004



Assortment with special hexagonal sockets and bits

- Compact bimaterial box with soft-touch covering
- Metal closing clip
- Socket size engraved inside

DESCRIPTION	ITEM/SIZE	PCS
Reversible ratchet with extension	237 1/4" SK	2
Hexagonal sockets with special profile	235 1/4" X 6-8-10-12-13	5
Bits for slot-head screws	660 0,5x4	1
Bits for PHILLIPS® screws	660 PH 2	1
Bits for Pozidriv® - Supadriv® screws	660 PZ 2	1
Socket-holder bit	660 Q 1/4"	1
Bits for TORX® Tamper Resistant screws	660 XSTX T20-T25-T30-T40	4
Bits with special hexagonal profile	660 X 2-2,5-3-4-5-6-7-8	8



38
PIECES



609 1/4" EAX U06090003



Assortment in bi-material case with hexagonal X-Grip sockets and bits

- Compact bi-material case with soft-touch coating
- Metal latch clip
- Internal marking of contained socket sizes

DESCRIPTION	ITEM/SIZE	PCS
Hexagonal sockets with special profile X-Grip	235 1/4" X 5,5-6-7-8-9-10-11-12-13-14 mm	10
Extensions	236 1/4" 50-100	2
Reversible ratchet with sealed mechanism	237 A 1/4"	1
Universal joint	241 1/4"	1
Spinner with handle	243 1/4"	1
Bits for slot-head screws	660 0,6x4,5-1x5,5-1,2x6,5	3
Bits for PH	660 PH 1-2-3	3
Bits for PZ	660 PZ 1-2-3	3
Bits with special profile X-Grip	660 X 2-3-4-5-6	5
Special Profile TORX® Tamper Resistant	660 XSTX T10-T15-T20-T25-T27-T30-T40	7
Bit-holder sockets	660 Q 1/4"	1
Socket-holder bit	684 1/4"-1/4"	1

8-10-11-12-13-14-15-16-17-18-
19-21-22-24-27-30-32 mm



STEEL HANDLE

The extension included in the set becomes the carrying handle.

1/2"

21
PIECES



System that allows you to always keep track of the contents of the set.



Internal marking of the contained sockets.

609 1/2" EAX
U06090027

3,7 kg | 55 mm | 180 mm

Assortment in bi-material case with hexagonal X-Grip sockets

- Bi-material case with soft-touch coating
- Metal latch clip
- Internal marking of contained socket sizes becomes the carrying handle
- Modularity: the case has the dimensions of a tool module and can be housed in the H60 mm drawers of trolleys

DESCRIPTION	ITEM/SIZE	PCS
Hexagonal sockets with special profile	235 1/2" X 8-10-11-12-13-14-15-16-17-18-19-21-22-24-27-30-32 mm	17
Extensions	236 1/2" 125-200	2
Reversible ratchet certified IP51	237 A 1/2"	1
Universal joint	241 1/2"	1

1/2"

5
PIECES

235 1/2" XL/C5
U02353900

1 kg | 44 mm | 115 mm

Assortment in bi-material case with long sockets featuring special X-Grip hex opening

- Compact bi-material case with soft-touch coating
- Metal latch clip
- Internal marking of contained socket sizes



15-17-19-21-22 mm



X-Grip MODULES FOR YOUR ROLLER CABINET!



519 M 613CEAX U05191068

22
PIECES

235 1/2" X 8-10-11-12-13-14-15-16-17-18-19-21-22-24-27-30-32 mm · 236 1/2" 125-250 mm · 237 A 1/2" · 240 1/2" N · 241 1/2".

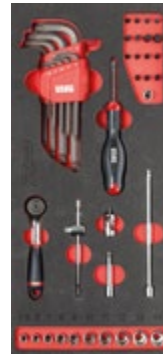

519 M 613AEAX U05191069

41
PIECES

235 1/4" X 5,5-6-7-8-9-10-11-12-13-14 mm · 236 1/4" 50-100 mm · 237 A 1/4" · 240 1/2" N · 241 1/4" · 243 1/4" · 280 X/S9" · 660 X 2-2,5-3-4-5-6-7-8 mm · 660 XSTX T10-T15-T20-T25-T27-T30-T40 · 684 1/4".

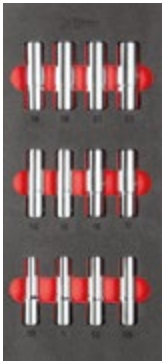

519 M 235XL U05191067

12
PIECES

235 1/2" XL 10-11-12-13-14-15-16-17-18-19-21-22 mm.



519 M 234X U05191017

16
PIECES

234 1/2" X 5-6-8-10-12-14-17-19 mm · 234 1/2" MX 5-6-8-10-12-14-17-19 mm.



519 M 285X U05191066

12
PIECES

285 X 8-9-10-11-12-13-14-15-16-17-18-19 mm.



519 M 280HX U05191064

6
PIECES

280 HX 2,5-3-4-5-6-8 mm.



519 M 280HXTX U05191066

6
PIECES

280 HXTX T8-T10-T15-T20-T25-T30.

**Do you want to add more
modules in your assortment?
Go to page 42**

MAINTENANCE ASSORTMENT



X-Grip Modules



519 M 280HXTX 519 M 280HX 519 M 234X



519 M 613AEAX 519 M 613CEAX 519 M 235 XL



519 M 127N 519 M 150AX 519 M 285X



519 M 990A5MD 519 M 382F 519 M 324H

516 ST6MXG

U05160639

RAL 3020

START roller cabinet with X-Grip MAINTENANCE assortment – 4 drawers

144
PIECES



6
DRAWERS

3
MODULES

DESCRIPTION

DESCRIPTION	ITEM	PCS
Internal and external circlip pliers, 19÷60 mm	519 M 127N	4
Universal pliers, adjustable pliers, diagonal cutter, long-nose pliers, and locking pliers	519 M 150AX	5
X-Grip hex sockets and impact sockets (5-6-8-10-12-14-17-19 mm)	519 M 234X	16
X-Grip long hex sockets 1/2" (10-11-12-13-14-15-16-17-18-19-21-22 mm)	519 M 235XL	12
X-Grip hex key wrenches with handle (2.5-3-4-5-6-8 mm)	519 M 280HX	6
X-Grip TORX® key wrenches with handle (T8-T10-T15-T20-T25-T30)	519 M 280HXTX	6
X-Grip combination wrenches (8-9-10-11-12-13-14-15-16-17-18-19 mm)	519 M 285X	12
Screwdrivers for slotted and PHILLIPS® screws	519 M 324H	8
Mechanic's hammer, mallet, pin punch, chisel, and center punch	519 M 382F	7
X-Grip hex sockets, 1/2" ratchet (237 A), and accessories	519 M 613AEAX	41
X-Grip hex sockets, 1/4" ratchet (237 A), accessories, X-Grip bits, and X-Grip hex key wrenches	519 M 613CEAX	22
Flat, half-round, round, square, and triangular files	519 M 990A5MD	5

516 ST6NMXXG

U05161639

RAL 9005

START roller cabinet with X-Grip MAINTENANCE assortment – 4 drawers

495 MXG

U04950639

X-Grip MAINTENANCE assortment – 4 drawers



144
PIECES



X-Grip Modules



519 M 280HXTX 519 M 280HX 519 M 234X



519 M 613AEAX 519 M 613CEAX 519 M 235 XL



519 M 127N 519 M 150AX 519 M 285X



519 M 990A5MD 519 M 382F 519 M 324H

Roller cabinets

RACING 519



YouTube

519 RACING ROLLER CABINET YOUR PREMIUM AND PROFESSIONAL WORKSHOP.



**TWO WHEELS
WITH BRAKE**

A new wider worktop
With double handle

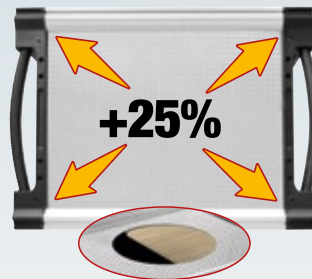

Double layer
Above: 2 mm aluminium plate.
Below: 15 mm wooden piece.



Rubber bumpers on
structure and drawers



New aluminium ergonomic handles
with selective opening



Save your time

All USAG roller cabinets are immediately ready for use, because they are supplied with the wheels already mounted on the structure



900 kg

**8
DRAWERS**
**3
MODULES**



900 kg

**7
DRAWERS**
**3
MODULES**



900 kg

**6
DRAWERS**

**3
MODULES**



519 RS6/3V
U05190506

RAL 3020

RACING roller cabinet (empty)

519 RS8/3V
U05190508

RAL 3020

RACING roller cabinet (empty)

- Inside dimensions:
 - 6 drawers 570x420x60 mm.
 - 2 drawers 570x420x130 mm.

519 RS7/3V
U05190507

RAL 3020

RACING roller cabinet (empty)

- Inside dimensions:
 - 5 drawers 570x420x60 mm.
 - 1 drawer 570x420x130 mm.
 - 1 drawer 570x420x200 mm.

519 RS6/3NV
U05190516

RAL 9005

RACING roller cabinet (empty)

- Inside dimensions:
 - 4 drawers 570x420x60 mm.
 - 1 drawer 570x420x130 mm.
 - 1 drawer 570x420x270 mm.

Roller cabinets

1000 kg



6
DRAWERS

4
MODULES

89 kg

mm

→ 1004
↑ 1005
↘ 575

519 RS6/4V
U05190546

RAL
3020

RACING roller cabinet (empty)

519 RS6/4NV
U05190566

RAL
9005

RACING roller cabinet (empty)

- Inside dimensions:
 - 4 drawers 760x420x60 mm.
 - 1 drawer 760x420x130 mm.
 - 1 drawer 760x420x270 mm.

1100 kg



7
DRAWERS

5
MODULES

106 kg

mm

→ 1194
↑ 1035
↘ 575

519 RS7/5V
U05190556

RAL
3020

RACING roller cabinet (empty)

- Inside dimensions:
 - 5 drawers 950x420x60 mm.
 - 1 drawer 950x420x130 mm.
 - 1 drawer 950x420x200 mm.

1100 kg



7
DRAWERS

3
MODULES

106 kg

mm

→ 1194
↑ 1035
↘ 575

519 RB07/3V
U05190097

RAL
3020

RACING roller cabinet with side door (empty)

- Inside dimensions:
 - 5 drawers 570x420x60 mm.
 - 1 drawer 570x420x130 mm.
 - 1 drawer 570x420x200 mm.
- Side compartment: 380x400x720 mm.



Roller cabinets



CAN'T FIND
Go now to



6
DRAWERS

3
MODULES



6
DRAWERS

3
MODULES

156
PIECES

519 RS6/3MM
U05190628

RAL
3020

519 RS6/3NMM
U05191628

RAL
9005

RACING roller cabinet with assortment for MAINTENANCE 495 MB - 4 drawers

155
PIECES

519 RS6/3MA
U05190627

RAL
3020

519 RS6/3NMA
U05191627

RAL
9005

RACING roller cabinet with AUTOMOTIVE assortment 495 MAA - 3 drawers

MAINTENANCE ASSORTMENT



519 M 613AEA 519 M 613CEA 519 M 285A1



519 M 127C 519 M 150AX 519 MSK6



519 M 324H 519 M 324STX 519 MSK6+
692 J32



519 M 990A5B 519 M 382 519 MSK6

DESCRIPTION	ITEM	PCS
Hexagonal sockets, ratchet (237 A 1/4"), accessories 1/4" and bits	519 M 613AEA	46
Hexagonal sockets, ratchet (237 A 1/2") and accessories 1/2"	519 M 613CEA	23
Combination wrenches (6-7-8-9-10-11-12-13-14-15-16-17-18-19-21-22-24 mm)	519 M 285A1	17
Pliers for circlips internal and external 15÷25 and 19÷60	519 M 127C	6
Universal pliers, adjustable pliers, cutting nippers, extra-long nose pliers, lock-grip pliers	519 M 150AX	5
Screwdrivers for slot-head and PHILLIPS® screws	519 M 324H	7
Screwdrivers for TORX® Tamper Resistant screws (T10-T15-T20-T25-T30-T40)	519 M 324STX	8
Flat square file, half-round file, round file, square file, triangular file (bastard cut)	519 M 990A5B	5
Hammer for mechanics with graphite handle, mallet, pin punches, chisel and centre punch	519 M 382F	7
Assortment with bits and reversible ratchet	692 J32	32

AUTOMOTIVE ASSORTMENT

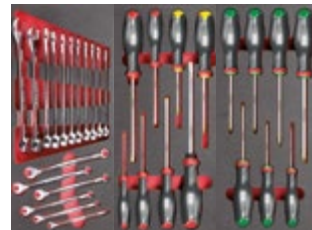

519 M 285A1 519 M 324H 519 M 324STX



519 M 613AEA 519 M 612CLA



519 M 276C



T-WRENCHES WITH JOINT
8-10-13-17 mm

DESCRIPTION	ITEM	PCS
Hexagonal sockets, ratchet (237 A 1/4"), accessories 1/4" and bits	519 M 613AEA	46
Bihexagonal sockets, ratchet (237 A 1/2") and accessories 1/2"	519 M 612CLA	35
Combination wrenches (6-7-8-9-10-11-12-13-14-15-16-17-18-19-21-22-24 mm)	519 M 285A1	17
Screwdrivers for slot-head and PHILLIPS® screws	519 M 324H	7
Screwdrivers for TORX® Tamper Resistant screws	519 M 324STX	8
Pliers for circlips, combination pliers, long nose pliers, T-handle wrenches with hex sockets (8-10-13-17 mm), bits set with ratchet	519 M 276C	42

YOUR IDEAL ASSORTMENT?
Kitplanner-gb.usag.it and create it!



6
DRAWERS

4
MODULES



6
DRAWERS

4
MODULES

301
PIECES

519 RS6/4MM
U05190632

RAL
3020

RACING roller cabinet with assortment
for **MAINTENANCE 495 MC - 4 drawers**



301
PIECES

519 RS6/4NMM
U05191632

RAL
9005

RACING roller cabinet with assortment
for **MAINTENANCE 495 MC - 4 drawers**



MAINTENANCE ASSORTMENT



519 M 612CLA

519 M 613BEA

519 M 613AEA

519 M 285KA

519 M 285A1

519 M 285A2

519 M 294B

519 M 324H

519 M 324STX

519 M 280HG

519 M 280N1

519 M 127C

519 M 150AX

519 M 382F

519 M 990A5MD

DESCRIPTION	ITEM	PCS
Hexagonal sockets, ratchet (237 A 1/4"), accessories 1/4" and bits	519 M 613AEA	46
Hexagonal sockets, ratchet (237 A 3/8") and accessories 3/8"	519 M 613BEA	20
Bihexagonal sockets, ratchet (237 A 1/2") and accessories 1/2"	519 M 612CLA	35
Reversible ratchet combination wrenches 8-9-10-11-12-13-14-15-16-17-18-19 mm	519 M 285 KA	12
Combination wrenches (6-7-8-9-10-11-12-13-14-15-16-17-18-19-21-22-24 mm)	519 M 285A1	17
Combination wrenches 27-29-30-32-34 mm	519 M 285A2	5
Adjustable wrenches, lock-grip pliers and scissor	519 M 294B	4
Screwdrivers for slot-head and PHILLIPS® screws	519 M 324H	7

DESCRIPTION	ITEM	PCS
Screwdrivers for TORX® Tamper Resistant screws (T10-T15-T20-T25-T30-T40)	519 M 324STX	8
Hexagon keys with handgrip (3-4-5-6-7-8-10 mm)	519 M 280HG	7
Set of keys for TORX® screws and assortment of bits with special shapes	519 M 280N1	117
Pliers for circlips internal and external 15÷25 and 19÷60	519 M 127C	6
Universal pliers, adjustable pliers, cutting nippers, extra-long nose pliers, lock-grip pliers	519 M 150AX	5
Flat square file, half-round file, round file, square file, triangular file (second cut)	519 M 990A5B	5
Hammer for mechanics with graphite handle, mallet, pin punches, chisel and centre punch	519 M 382F	7

Do you want only the assortment? Go to page 40

Roller cabinets

START⁵¹⁶



YouTube

516 START ROLLER CABINET MORE RESISTANT AND RELIABLE.



New worktop 460 x 560 mm
with 15 mm sides



High resistance 35 mm slides
with a load capacity up to 40 kg



New drawer handles in high resistant
ABS with selective opening



Save your time

All USAG roller cabinets are immediately ready for use, because they are supplied with the wheels already mounted on the structure.



800 kg

5
DRAWERS

3
MODULES

54 kg | 779 mm | 972 mm | 515 mm



800 kg

6
DRAWERS

3
MODULES

55 kg | 779 mm | 972 mm | 515 mm



800 kg

7
DRAWERS

3
MODULES

56 kg | 779 mm | 972 mm | 515 mm

516 ST5V
U05160105

RAL 3020

START roller cabinet (empty)

- Inside dimensions:
 - 2 drawers 570x420x60 mm.
 - 2 drawers 570x420x130 mm.
 - 1 drawer 570x420x270 mm.

516 ST6V
U05160106

RAL 3020

START roller cabinet (empty)

516 ST6NV
U05160116

RAL 9005

START roller cabinet (empty)

- Inside dimensions:
 - 3 drawers 570x420x60 mm.
 - 2 drawers 570x420x130 mm.
 - 1 drawer 570x420x200 mm.

516 ST7V
U05160107

RAL 3020

START roller cabinet (empty)

516 ST7NV
U05160117

RAL 9005

START roller cabinet (empty)

- Inside dimensions:
 - 5 drawers 570x420x60 mm.
 - 1 drawer 570x420x130 mm.
 - 1 drawer 570x420x200 mm.

Roller cabinets



8
DRAWERS

3
MODULES

58 kg | mm | 779
972
515

516 ST8V
U05160108

RAL 3020

START roller cabinet (empty)

- Inside dimensions:
 - 6 drawers 570x420x60 mm.
 - 2 drawers 570x420x130 mm.



6
DRAWERS

4
MODULES

68 kg | mm | 969
972
515

516 STXL6V
U05160146

RAL 3020

START roller cabinet (empty)

- Inside dimensions:
 - 3 drawers 760x420x60 mm.
 - 2 drawers 760x420x130 mm.
 - 1 drawer 760x420x200 mm.



6
DRAWERS

4
MODULES

68 kg | mm | 969
972
515

516 STXL6NV
U05160156

RAL 9005

START roller cabinet (empty)

- Inside dimensions:
 - 3 drawers 760x420x60 mm.
 - 2 drawers 760x420x130 mm.
 - 1 drawer 760x420x200 mm.



Anti-tilt system



7
DRAWERS

3
MODULES

58 kg | mm | 779
972
515

516 STS7V
U05160127

RAL 3020

START roller cabinet (empty)

516 STS7NV
U05160137

RAL 9005

START roller cabinet (empty)

- Inside dimensions:
 - 5 drawers 570x420x60 mm.
 - 1 drawer 570x420x130 mm.
 - 1 drawer 570x420x200 mm.



6
DRAWERS

3
MODULES

72 kg | mm | 969
972
515

516 STB06V
U05160097

RAL 3020

START roller cabinet with vertical drawer (empty)

- Inside dimensions:
 - 3 drawers 570x420x60 mm.
 - 2 drawers 570x420x130 mm.
 - 1 drawer 570x420x270 mm.



VERTICAL DRAWER
on the right side with 3 shelves and independent locking

Roller cabinets



CAN'T FIND
Go now to



6
DRAWERS

3
MODULES



6
DRAWERS

3
MODULES

157
PIECES

516 ST6PM
U05160630

RAL
3020



516 ST6NPM
U05161630

RAL
9005

START roller cabinet with MAINTENANCE assortment 495 PM - 4 drawers

142
PIECES

516 ST6PA
U05160629

RAL
3020



516 ST6NPA
U05161629

RAL
9005

START roller cabinet with AUTOMOTIVE assortment 495 PA - 2 drawers

MAINTENANCE ASSORTMENT



519/613AEA

519/613CEA

519 SK692V

519/285A1

519/150AX

519 SK692V



519/324H

519/324TX

519 SK692V + 692 J32

519 SK692V

519/990A1

519/382F

AUTOMOTIVE ASSORTMENT



519/613AEA

519/613CEA

519 SK692V + 692 J32

519/324H

519/285A1

519/150AX



T-WRENCHES WITH JOINT
7-8-10-12-13-17 mm

DESCRIPTION	ITEM	PCS
Hexagonal sockets, ratchet (237 A 1/4"), accessories 1/4" and bits	519/613AEA	42
Hexagonal sockets, ratchet (237 A 1/2") and accessories 1/2"	519/613CEA	22
Combination wrenches (6÷24 mm) and angled keys (1,5÷10 mm)	519/285A1	25
Universal pliers, adjustable pliers, cutting nippers, extra-long nose pliers, lock-grip pliers	519/150AX	5
Screwdrivers for slot-head and PHILLIPS® screws	519/324H	10
Screwdrivers for TORX® screws	519/324TX	9
Flat square file, half-round file, round file, triangular file (second cut)	519/990A1	4
Hammers, chisels and pin punches	519/382F	8
Assortment with bits and reversible ratchet	692 J32	32

DESCRIPTION	ITEM	PCS
Hexagonal sockets, ratchet (237 A 1/4"), accessories 1/4" and bits	519/613AEA	42
Hexagonal sockets, ratchet (237 A 1/2") and accessories 1/2"	519/613CEA	22
Screwdrivers for slot-head and PHILLIPS® screws	519/324H	10
Combination wrenches (6÷24 mm) and angled keys (1,5÷10 mm)	519/285A1	25
Universal pliers, adjustable pliers, cutting nippers, extra-long nose pliers, lock-grip pliers	519/150AX	5
T-handle wrenches with jointed hexagonal socket (7-8-10-12-13-17 mm)	276 CE	6
Assortment with bits and reversible ratchet	692 J32	32

Do you want only the assortment? Go to page 41

YOUR IDEAL ASSORTMENT?
Kitplanner-gb.usag.it and create it!



6
DRAWERS

3
MODULES



6
DRAWERS

3
MODULES

156
PIECES

516 ST6MM
U05160628

RAL
3020



516 ST6NMM
U05161628

RAL
9005

START roller cabinet with assortment for MAINTENANCE 495 MB - 4 drawers

155
PIECES

516 ST6MA
U05160627

RAL
3020



516 ST6NMA
U05161627

RAL
9005

START roller cabinet with AUTOMOTIVE assortment 495 MAA - 3 drawers

MAINTENANCE ASSORTMENT



519 M 613AEA 519 M 613CEA 519 M 285A1



519 M 127C 519 M 150AX 519 MSK6



519 M 324H 519 M 324STX 519 MSK6+
692 J32



519 M 990A5B 519 M 382 519 MSK6

AUTOMOTIVE ASSORTMENT

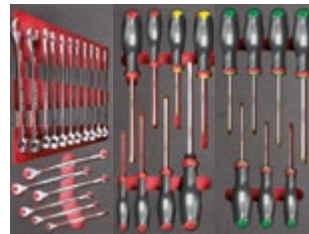

519 M 285A1 519 M 324H 519 M 324STX



519 M 613AEA 519 M 612CLA



519 M 276C



T-WRENCHES WITH JOINT

8-10-13-17 mm

DESCRIPTION	ITEM	PCS
Hexagonal sockets, ratchet (237 A 1/4"), accessories 1/4" and bits	519 M 613AEA	46
Hexagonal sockets, ratchet (237 A 1/2") and accessories 1/2"	519 M 613CEA	23
Combination wrenches (6-7-8-9-10-11-12-13-14-15-16-17-18-19-21-22-24 mm)	519 M 285A1	17
Pliers for circlips internal and external 15÷25 and 19÷60	519 M 127C	6
Universal pliers, adjustable pliers, cutting nippers, extra-long nose pliers, lock-grip pliers	519 M 150AX	5
Screwdrivers for slot-head and PHILLIPS® screws	519 M 324H	7
Screwdrivers for TORX® Tamper Resistant screws	519 M 324STX	8
Flat square file, half-round file, round file, square file, triangular file (second cut)	519 M 990A5B	5
Hammer for mechanics with graphite handle, mallet, pin punches, chisel and centre punch	519 M 382F	7
Assortment with bits and reversible ratchet	692 J32	32

DESCRIPTION	ITEM	PCS
Hexagonal sockets, ratchet (237 A 1/4"), accessories 1/4" and bits	519 M 613AEA	46
Bihexagonal sockets, ratchet (237 A 1/2") and accessories 1/2"	519 M 612CLA	35
Combination wrenches (6-7-8-9-10-11-12-13-14-15-16-17-18-19-21-22-24 mm)	519 M 285A1	17
Screwdrivers for slot-head and PHILLIPS® screws	519 M 324H	7
Screwdrivers for TORX® Tamper Resistant screws	519 M 324STX	8
Pliers for circlips, combination pliers, long nose pliers, T-handle wrenches with hex sockets (8-10-13-17 mm), bits set with ratchet	519 M 276C	42

Do you want only the assortment? Go to page 40

Roller cabinets



CAN'T FIND
Go now to



6
DRAWERS

4
MODULES



6
DRAWERS

4
MODULES

301
PIECES

516 STXL6MM
U05160632

RAL
3020

START XL roller cabinet with assortment for MAINTENANCE 495 MC - 4 drawers



301
PIECES

516 STXL6NMM
U05161632

RAL
9005

START XL roller cabinet with assortment for MAINTENANCE 495 MC - 4 drawers



MAINTENANCE ASSORTMENT



519 M 612CLA

519 M 613BEA

519 M 613AEA

519 M 285KA

519 M 285A1

519 M 285A2

519 M 294B

519 M 324H

519 M 324STX

519 M 280HG

519 M 280N1

519 M 127C

519 M 150AX

519 M 382F

519 M 990A5MD

DESCRIPTION	ITEM	PCS	DESCRIPTION	ITEM	PCS
Hexagonal sockets, ratchet (237 A 1/4"), accessories 1/4" and bits	519 M 613AEA	46	Screwdrivers for TORX® Tamper Resistant screws	519 M 324STX	8
Hexagonal sockets, ratchet (237 A 3/8") and accessories 3/8"	519 M 613BEA	20	Hexagon keys with handgrip (3-4-5-6-7-8-10 mm)	519 M 280HG	7
Bihexagonal sockets, ratchet (237 A 1/2") and accessories 1/2"	519 M 612CLA	35	Set of keys for TORX® screws and assortment of bits with special shapes	519 M 280N1	117
Reversible ratchet combination wrenches 8-9-10-11-12-13-14-15-16-17-18-19 mm	519 M 285 KA	12	Pliers for circlips internal and external 15÷25 and 19÷60	519 M 127C	6
Combination wrenches (6-7-8-9-10-11-12-13-14-15-16-17-18-19-21-22-24 mm)	519 M 285A1	17	Universal pliers, adjustable pliers, cutting nippers, extra-long nose pliers, lock-grip pliers	519 M 150AX	5
Combination wrenches 27-29-30-32-34 mm	519 M 285A2	5	Flat square file, half-round file, round file, square file, triangular file (second cut)	519 M 990A5B	5
Adjustable wrenches, lock-grip pliers and scissor	519 M 294B	4	Hammer for mechanics with graphite handle, mallet, pin punches, chisel and centre punch	519 M 382F	7
Screwdrivers for slot-head and PHILLIPS® screws	519 M 324H	7			

Do you want only the assortment? Go to page 40

YOUR IDEAL ASSORTMENT?
Kitplanner-gb.usag.it and create it!



6
DRAWERS

3
MODULES



6
DRAWERS

3
MODULES

264
PIECES



516 ST6MMEX
U05160634

RAL
3020

START roller cabinet with assortment for MAINTENANCE 495 MMEX - 3 drawers

264
PIECES



516 ST6MMEX
U05161634

RAL
9005

START roller cabinet with assortment for MAINTENANCE 495 MMEX - 3 drawers

264
PIECES



495 MMEX
U04950634

Assortment for MAINTENANCE - 3 drawers

MAINTENANCE ASSORTMENT



519 M 601



519 M 324H

519 M 324STX

519 M 280N1



519 M 127N

519 M 150AX

519 M 382F

DESCRIPTION	ITEM	PCS
Universal pliers, adjustable pliers, cutting nippers, extra-long nose pliers, lock-grip pliers	519 M 150AX	5
Pliers for circlips internal and external 19÷60	519 M 127N	4
Set of keys for TORX® screws and assortment of bits with special shapes	519 M 280N1	117
Screwdrivers for slot-head and PHILLIPS® screws	519 M 324H	7
Screwdrivers for TORX® Tamper Resistant screws	519 M 324STX	8

DESCRIPTION	ITEM	PCS
Hammer for mechanics with graphite handle, mallet, pin punches, chisel and centre punch	519 M 382F	7
Adjustable wrenches, lock-grip pliers and scissor, Hexagonal sockets 1/4" 4÷14 mm - 1/2" 10÷32 mm, Long hexagonal sockets 1/4" 6÷14 mm - 1/2" 13÷22 mm, Socket bits 1/4" for PH, PZ, slot-head, hexagonal, Torx screw, Ratchet and accessories 1/4" - 1/2", Spark plug sockets 1/2" 16-21 mm, Torx sockets 1/4" - 1/2" E6÷ E24, Bits 5/16" for PH, PZ, slot-head, hexagonal, Torx, XZN screw	519 M 601	116



FURNITURE LINE START 516 PROFESSIONAL WORKSTATION



QUALITY OF START RANGE



High resistance 35 mm slides with a load capacity up to 40 kg.
Handles in high resistant ABS.

WORKTOP, STEEL OR WOOD, LARGE AND DURABLE

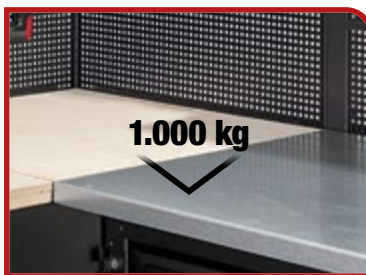

Depth: 600 mm.
Static load capacity: 1000 Kg.

COMPATIBLE WITH USAG MODULARITY

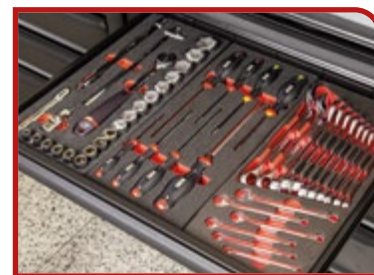

The drawers are compatible with the USAG foam modules or plastic trays system present in the Catalog.

CHOOSE YOUR IDEAL LAY-OUT

Try it now: go to start516-gb.usag.it





Assortment of 302 tools included



302
PIECES



DESCRIPTION	ITEM	PCS
Base unit with 6 drawers	516 SA/1T	1
Base unit with 2 doors	516 SA/2T	1
Pegboards	516 SA5T	6
Top chests with tilting door	516 SA/4T	3
Cabinet with 1 door	516 SA/3T	1
START roller cabinet - 6 drawers (empty)	516 SA/16T	1
Fitting kits	516 SA14T	3
Raising support	516 SA11T	3



516 SA/STBP RAL 9005
U05160318

288 kg mm 2.675 2.000 650

Workshop furniture with assortment

Steel top
2.175 mm - 516 AC/2

Hooks and lamps not included



DESCRIPTION	ITEM	PCS
Base unit with 6 drawers	516 SA/1T	1
Base unit with 2 doors	516 SA/2T	1
Pegboard	516 SA5T	6
Top chest with tilting door	516 SA/4T	3
Cabinet with 1 door	516 SA/3T	1
START roller cabinet - 6 drawers (empty)	516 SA/16T	1
Fitting kit	516 SA14T	3
Raising support	516 SA11T	3

Hooks and lamps not included



516 SA/STAP RAL 9005
U05160318

288 kg mm 2.675 2.000 650

Workshop furniture - steel worktop

Steel top
2.175 mm - 516 AC/2



516 SA/STLP RAL 9005
U05160314

277 kg mm 2.675 2.000 650

Workshop furniture - wooden worktop

Wooden top
2.175 mm - 516 SAL/2



CHOOSE YOUR

Try it now: go to



Complete configuration
INCLUDES: HOOKS, LED LIGHTS, POWER STRIP, AND DRAWERS ON WHEELS

DESCRIPTION	ITEM	PCS
Base unit with 7 drawers	516 SA1T/7	1
Base unit with bin and paper roll holder	516 SA17T	1
Pegboard	516 SA5T	5
Pegboard with power strip (3 SCHUKO plug and 2 USB doors)	516 SA6T	1
Top chest with tilting door	516 SA/4T	3
Cabinet with 2 door	516 SA3T/2	1
START roller cabinet - 6 drawers (empty)	516 SA/16T	1
Rack for power tools	516 SA4TP	1
Open drawer on wheels	516 SA20T	2
LED lamps	516 SA/12	2
Fitting kit	516 SA14T	3
Raising support	516 SA11T	3



STEEL

Steel top
2.175 mm - 516 AC/2

516 SA/PRA
U05160295

RAL 9005



Workshop furniture - steel top

- Supplied with 40 hooks (kit 516 SA/K1)



WOOD

Wooden top
2.175 mm - 516 SAL/2

516 SA/PRL
U05160296

RAL 9005



Workshop furniture - wooden top

- Supplied with 40 hooks (kit 516 SA/K1)



Complete configuration
INCLUDES: HOOKS, LED LIGHTS, POWER STRIP, AND DRAWERS ON WHEELS

DESCRIPTION	ITEM	PCS
Base unit with 6 drawers	516 SA/1T	1
Base unit with 2 doors	516 SA/2T	1
Pegboard	516 SA5T	3
Pegboard with power strip (3 SCHUKO plug and 2 USB doors)	516 SA6T	1
Top chest with tilting door	516 SA/4T	2
Cabinet with 1 door	516 SA/3T	1
Open drawer on wheels	516 SA20T	2
Fitting kit	516 SA14T	2
Raising support	516 SA11T	3



STEEL

Steel top
1.450 mm - 516 AC/1

516 SA/CA
U05160291

RAL 9005



Workshop furniture - steel top

- Supplied with 40 hooks (kit 516 SA/K1)



WOOD

Wooden top
1.450 mm - 516 SAL/1

516 SA/CL
U05160292

RAL 9005



Workshop furniture - wooden top

- Supplied with 40 hooks (kit 516 SA/K1)

IDEAL LAY-OUT
start516-gb.usag.it

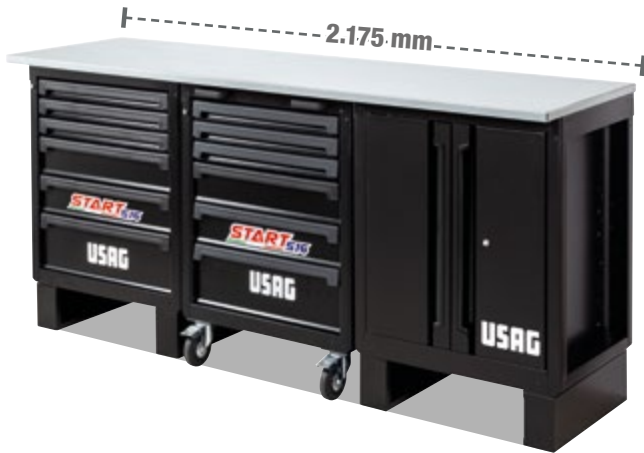

DESCRIPTION	ITEM	PCS
Base unit with 6 drawers	516 SA/1T	1
Base unit with 2 doors	516 SA/2T	1
Roller cabinet START - 6 drawers (empty)	516 SA/16T	1
Raising support	516 SA11T	2



516 SA/BCA
U05160289

RAL 9005



Workstation with sheet steel top

Steel top
2.175 mm - 516 AC/2



516 SA/BCL
U05160290

RAL 9005



Workstation with wooden top

Wooden top
2.175 mm - 516 SAL/2



DESCRIPTION	ITEM	PCS
Steel top 2175 mm	516 SA1T/6	1
Raising support	516 SA11T	2
Upright for furniture line	516 SAM	1



516 SA/BC2A
U05160322

RAL 9005



Workstation with sheet steel top

Steel top
2.175 mm - 516 AC/2



516 SA/BC2L
U05160323

RAL 9005



Workstation with wooden top

Wooden top
2.175 mm - 516 SAL/2



516 SA/BC1A
U05160324

RAL 9005



Workstation with sheet steel top

Steel top
1.450 mm - 516 AC/1



516 SA/BC1L
U05160325

RAL 9005



Workstation with wooden top

Wooden top
1.450 mm - 516 SAL/1



WORKBENCH SYSTEM 506 TOP RESISTANCE AND STABILITY



ACCESSORIES

Compatible with 516 AC line
(only 506 KA and KL models)



LARGE DRAWERS

mounted on high quality slides

2.000 kg



2.000 kg



506 KA U05060256



Workstation with sheet steel top

- Galvanized sheet steel top (thickness 3 mm) with sides 37 mm
- Durable structure with 6 uprights
- Double fully opening drawers, with locking
- Metal sheet-steel doors with adjustable hinges
- Lower shelf included
- Possibility to hang 516 accessories in the lateral sides
- Arranged for ground fixing
- Static load capacity: 2000 kg
- Internal drawers dimension: 830x550x110 mm
- Internal compartments with doors dimension: 860x350x440 mm
- RAL 9005 painted steel
- Supplied disassembled

506 KL U05060246



Workstation with wooden top

- Multilayer wooden top, thickness 30 mm
- Durable structure with 6 uprights
- Double fully opening drawers, with locking
- Metal sheet-steel doors with adjustable hinges
- Lower shelf included
- Possibility to hang 516 accessories in the lateral sides
- Arranged for ground fixing
- Static load capacity: 2000 kg
- Internal drawers dimension: 830x550x110 mm
- Internal compartments with doors dimension: 860x350x440 mm
- RAL 9005 painted steel
- Supplied disassembled



506 TAC

RAL 9005

STEEL

Workbench with sheet steel top

- Galvanized sheet steel top (thickness 3 mm) with sides 37 mm
- Metal sheet-steel doors uprights and lower shelf, thickness 1,2 mm
- Side holes for fixing multiple benches side by side.
- Arranged for ground fixing
- 6 uprights for size 2 m
- Gap between 2 uprights: 864 mm
- Gap between lower shelf and worktop: 525 mm
- Internal drawer dimensions:
L 1000 and L 2000: 830x550x110 mm
L 1500: 1280x550x110 mm
- Supplied disassembled

CODE	DIMENSIONS LxPxH	Weight	N° drawers
U05060154	1046x700x910 mm	65 kg	1
U05060155	1500x700x910 mm	85 kg	1
U05060156	2000x700x910 mm	110 kg	2

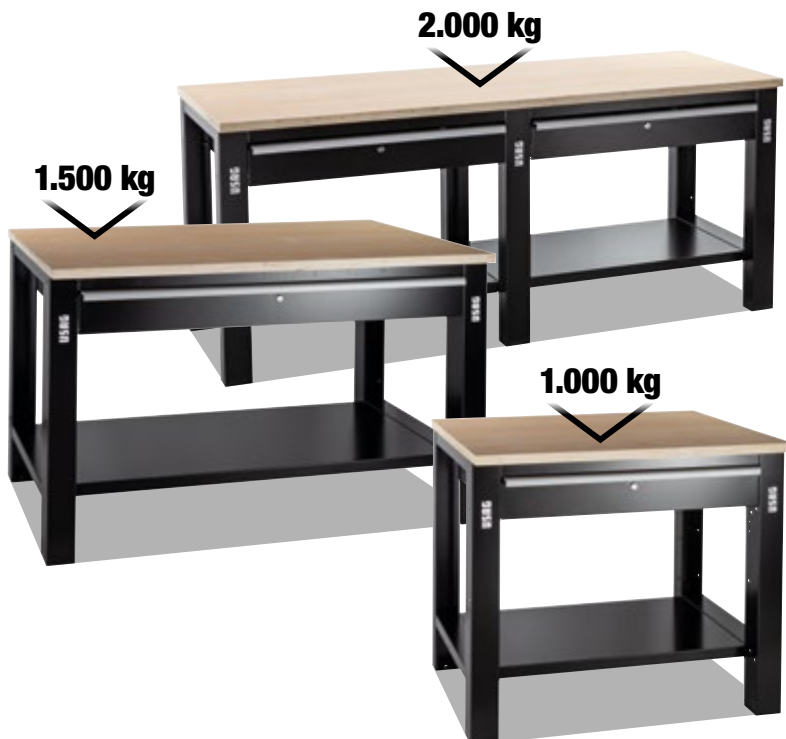

506 TLC

RAL 9005

WOOD



Workbench with wooden top

- Multilayer wooden top, thickness 30 mm
- Metal sheet-steel doors uprights and lower shelf, thickness 1,2 mm
- Side holes for fixing multiple benches side by side.
- Arranged for ground fixing
- 6 uprights for size 2 m
- Gap between 2 uprights: 864 mm
- Gap between lower shelf and worktop: 525 mm
- Internal drawer dimensions:
L 1000 and L 2000: 830x550x110 mm
L 1500: 1280x550x110 mm
- Supplied disassembled

CODE	DIMENSIONS LxPxH	Weight	N° drawers
U05060144	1046x700x910 mm	55 kg	1
U05060145	1500x700x910 mm	75 kg	1
U05060146	2000x700x910 mm	100 kg	2



506 KD

Divider kit for drawers 506 TC

- Compatibility:
 - 506 KD1: for drawer 506 TC1;
 - 506 KD2: for drawer 506 TC2

CODE	SIZE	Weight
U05060156Q	1	3 kg
U05060157Q	2	5 kg

Workbenches

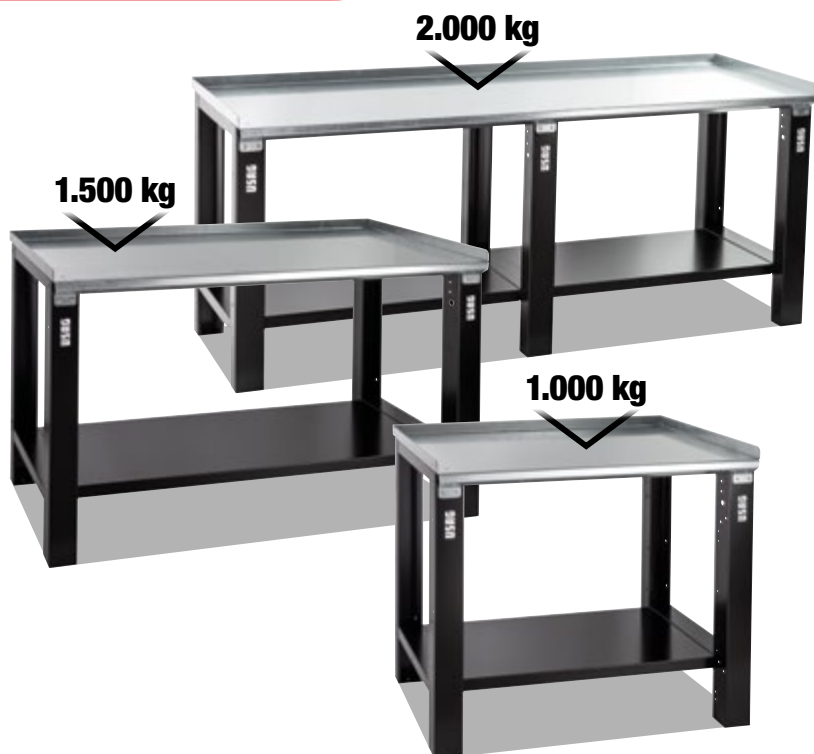

506 TA

RAL 9005

STEEL

Workbench with sheet steel top

- Galvanized sheet steel top (thickness 3 mm) with sides 37 mm
- Metal sheet-steel doors uprights and lower shelf, thickness 1,2 mm
- Side holes for fixing multiple benches side by side.
- Arranged for ground fixing
- 6 uprights for size 2 m
- Gap between 2 uprights: 864 mm
- Gap between lower shelf and worktop: 660 mm
- Supplied disassembled

CODE	DIMENSIONS LxPxH	Weight
U05060054	1046x700x910 mm	50 kg
U05060055	1500x700x910 mm	60 kg
U05060056	2000x700x910 mm	80 kg



506 TL

RAL 9005



WOOD

Workbench with wooden top

- Multilayer wooden top, thickness 30 mm
- Metal sheet-steel doors uprights and lower shelf, thickness 1,2 mm
- Side holes for fixing multiple benches side by side.
- Arranged for ground fixing
- 6 uprights for size 2 m
- Gap between 2 uprights: 864 mm
- Gap between lower shelf and worktop: 660 mm
- Supplied disassembled

CODE	DIMENSIONS LxPxH	Weight
U05060044	1046x700x910 mm	40 kg
U05060045	1500x700x910 mm	50 kg
U05060046	2000x700x910 mm	70 kg



506 TC

RAL 9005

Drawers for workbenches

- Compatibility with 506 TA and 506 TL models
- Slides with load resistance up to 60 kg

CODE	MIS	INT. DIMENSIONS LxPxH	Weight
U05060154Q	1	830x550x110 mm	15 kg
U05060155Q	2	1280x550x110 mm	25 kg

1
DRAWER

3
SHELVES



New

506 TAS
U05060257



STEEL

Workbench with steel top and 3-shelf utility cart

1
DRAWER

3
SHELVES



New

506 TLS
U05060247



WOOD



Workbench with wooden top and 3-shelf utility cart



COMPATIBILITY WITH 506 TA AND TL BENCHES

2 pairs of wheels for 1000 and 1500 models, 3 pairs of wheels for 2000 models.

200 kg



UNDER TOP UTILITY CART

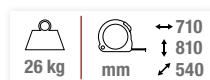

3
SHELVES



New



506 TR
U05060158Q

Wheel kit for workbenches

- Kit composed of two swiveling wheels Ø100 mm
- Benches 1000 and 1500: maximum static load capacity with wheels 500 kg
- Benches 2000: maximum static load capacity with wheels 900 kg
- Wheel supports in galvanized steel sheet

516 SN
U05160265

RAL 9005

Three-Shelf multi-purpose roller cabinet

- 3 shelves measuring 500x700 mm
- Shelves covered with 2 mm ABS mats
- 37 mm anti-fall edges on all 3 shelves
- Double front handle in ABS
- Four swiveling wheels (Ø 100 mm), two with brakes
- Supplied disassembled
- Maximum load capacity: 200 kg
- Structure painted in black RAL 9005

506 TP
U05060159Q

RAL 9005

Pair of uprights for perforated panel

- Allow the 501 P panels to be fixed to workbenches 506 TA, 506 TL, and 506 K
- Compatible with all 506 workbench models, both with steel and wooden tops
- Suitable for all bench sizes: 1000, 1500, 2000

Utility chart



504 SR U05040004

RAL 3020

Three-shelf utility chart

- 3 shelves 770x448 mm
- Shelves covered by 2 mm ABS mats
- 37 mm anti-fall edges on all 3 shelves
- Steel handle Ø 25 mm
- Possibility to hang 516 accessories in the lateral sides
- Two fixed and two swivelling (Ø 100 mm), one of which has a brake
- Supplied disassembled
- Maximum loading capacity: 200 Kg

504 SN U05040014

RAL 9005

Three-shelf utility chart

- 3 shelves 770x448 mm
- Shelves covered by 2 mm ABS mats
- 37 mm anti-fall edges on all 3 shelves
- Steel handle Ø 25 mm
- Possibility to hang 516 accessories in the lateral sides
- Two fixed and two swivelling (Ø 100 mm), one of which has a brake
- Supplied disassembled
- Maximum loading capacity: 200 Kg

504 SNA U05040015

RAL 9005

Three-shelf utility chart

- 3 shelves 770x448 mm
- Shelves covered by 2 mm ABS mats
- 37 mm anti-fall edges on all 3 shelves
- Steel handle Ø 25 mm
- Possibility to hang 516 accessories in the lateral sides
- Two fixed and two swivelling (Ø 100 mm), one of which has a brake
- Drawer with slides (load capacity up to 20 kg)
- Double key supplied
- Supplied disassembled
- Maximum loading capacity: 200 Kg

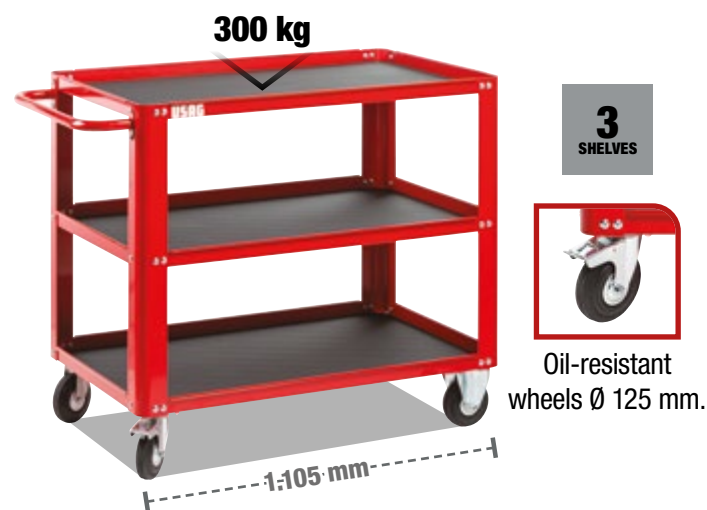

504 SRXL U05040005

RAL 3020



Three-shelf utility chart XL

- 3 shelves measuring 600x970 mm
- Shelves covered with 2 mm ABS mats
- 37 mm anti-fall edges on all 3 shelves
- Tubular steel handle with a diameter of 25 mm
- Two swiveling wheels and two fixed wheels (Ø 125 mm), one with brake
- Supplied disassembled
- Maximum load capacity: 300 kg
- Structure painted in red RAL 3020

503 T U05030002



Multi-purpose chart with folding handle

- Loading platform in galvanized sheet metal with reinforcement bars underneath
- Wide tubular steel handle, foldable onto the platform for compact transport
- Four rubber wheels Ø 125 mm, two fixed and two swiveling, one with brake
- Usable dimensions of loading platform: 760x560 mm
- Height of loading platform from the ground: 158 mm

YOUR NEW MOBILE WORKSTATION



12
DRAWERS

3
MODULES



Overhanging top for use with clamps.

1.200 kg



516 STBU12V

U05160098

RAL 9005



START mobile workbench (empty)

- Worktop in 30 mm thick plywood
- Worktop dimensions: 1,350x800 mm
- Possibility to mount a bench vise or use bar clamps on the lateral overhangs of the worktop
- Double tubular steel transport handle
- Full-extension drawers on ball bearing telescopic slides
- Oil-resistant rubber mats inside the drawers
- Oil-resistant rubber wheels (Ø 160 mm): two fixed and four swivel with brake
- Supplied with 4 bottle holders that can be positioned on the sides of the drawer units
- Side panels and rear panel prepared for mounting optional accessories
- Storage cabinet with lockable door and 3 internal shelves
- Two side drawers with independent locks
- Supplied with wheels already assembled to the structure
- Maximum drawer load capacity: 40 kg
- Internal drawer dimensions:
 - 3 drawers 570x420x60 mm;
 - 2 drawers 570x420x130 mm;
 - 1 drawer 570x420x270 mm.
- Internal dimensions of side cabinet: 310x310x74 mm
- Internal dimensions of side drawers: 285x335x300 mm

ALL-ROUND OPERABILITY

One workbench, four sides, endless possibilities: work anywhere, from any angle!

MOVE WITHOUT LIMITS

Thanks to its 6 wheels, including 4 swivel casters, the workbench rotates 360°, offering maximum mobility even in the tightest spaces.



360°

ACCESSORIES FOR ROLLER CABINETS AND DRAWER UNITS

New



516 AT1

U05160401

Paper roll holder for roller cabinets and drawer units

- Side accessory for RACING 519, START 516, and JUST 515 roller cabinets
- Also suitable for START 516 furniture base units and the sides of 506 K workbenches

New



516 AT2

U05160402

Bottle holder for roller cabinets and drawer units

- Side accessory for RACING 519, START 516, and JUST 515 roller cabinets
- Also suitable for START 516 furniture base units and the sides of 506 K workbenches

100 kg



72
Liters

87
Liters

103
Liters

532 T

RAL 3020

Professional metal chest

- Side design engineered to increase structural rigidity
- Zinc-plated steel lid hinges with a stop point at 105° opening
- Structure made of red RAL 3020 painted steel sheet

CODE	L (mm)	P (mm)	H (mm)	Weight
B U05320016	700	350	350	14 kg
C U05320017	850	350	350	16 kg
D U05320018	1000	350	350	18 kg



Very large carrying handles, integrated into the side panels



532 TK

U05320001Q

Set of Risers for metal chest

- Compatible with tool case 532 T
- 3 mm thick galvanized steel sheet



DESIGNED TO ALLOW THE POSSIBILITY OF TRANSPORTING THE TOOL CASE WITH A FORKLIFT OR PALLET JACK.

MAX
20 kg

4,7 kg | mm | 465
352
215



001 RV U00010004

Tool case in high thickness polypropilene (empty)

- Two inside removable panels with elastics to hold tools
- Lower compartment with mobile separators
- Double key lock

MAX
20 kg

6 kg | mm | 465
352
255



001 TRV U00010005

Tool trolley in high thickness polypropilene (empty)

- Telescopic Aluminium handle
- Wheels with integrated roll bearings



5
COMPARTMENTS

6,6 kg | mm | 560
320
220



646/5LV U06460301

Long cantilever tool box, five compartments (empty)

- Preset for padlock
- Sheet steel casing, anaphoretic process

8
COMPARTMENTS

1,5 kg | mm | 422
106
335



640 A U06400001

Organizer (empty)

- Transparent cover: contents visible
- 8 removable compartments one of which can be further divided with the 2 dividers provided

641 T

Tool box (empty)

- High resistant plastic material
- 2 compartments for small objects on the cover
- Possibility to close with a padlock (not supplied)
- Foldaway handle
- Inside removable tray



	CODE	L (mm)	P (mm)	H (mm)	Weight	
A	U06410004	16"	394	220	162	1,2 kg
B	U06410005	19"	486	266	236	2,1 kg
C	U06410006	24"	595	281	260	2,8 kg

Portable storage



YouTube



5,4 kg	mm	↔ 550 ↑ 440 ↙ 360	MAX 18 kg	CAPACITY 33 L
--------	----	-------------------------	---------------------	-------------------------

007 TXV U00070065

Trolley tool bag (empty)

- Model in high strength fabric
- Telescopic Aluminium handle
- 6 external pockets and 1 front pocket for a saw
- Toolholder compartments
- Aluminium handle with covered handgrip
- Soft top cover with Velcro
- Maximum loading capacity: 18 kg



4 kg	mm	↔ 490 ↑ 350 ↙ 220	MAX 15 kg	CAPACITY 47 L
------	----	-------------------------	---------------------	-------------------------

007 V U00070002

Professional tool bag (empty)

- Model in high strength fabric
- Rigid waterproof bottom
- Toolholder compartments and front pocket for a saw
- Aluminium handle with covered handgrip
- Transport shoulder strap
- Soft top cover with Velcro



2,5 kg	mm	↔ 420 ↑ 340 ↙ 240	MAX 11 kg	CAPACITY 34 L
--------	----	-------------------------	---------------------	-------------------------

007/1V U00070001

Professional tool bag (empty)

- Model in high strength fabric
- Rigid waterproof bottom
- Inside space for tools
- Aluminium handle with covered handgrip
- 2 front pockets for small objects, 1 side pocket with Velcro closure, 1 side open pocket for quick access to contents, 4 rear pockets protected by the soft top
- 1 pocket with 4 elastics to hold tools and 11 elastics for screwdrivers
- Soft top cover with Velcro



3,1 kg	mm	↔ 355 ↑ 225 ↙ 460
--------	----	-------------------------

MAX 12 kg

CAPACITY 30 L



007 SV U00070004

Professional backpack (empty)

- High strength fabric
- Adjustable chest strap
- Padded waist straps to distribute the weight evenly
- Rigid waterproof bottom
- Inside tool-holding space
- Side and front pockets
- Inside document holder
- Maximum loading capacity: 12 kg



1 kg	mm	↔ 360 ↑ 280 ↙ 190
------	----	-------------------------

MAX 10 kg

CAPACITY 15 L

007 MCV U00070008

Tool bag (empty)

- Model in high strength Fabric
- Rigid waterproof bottom
- Internal toolholder compartments
- 3 front pockets with soft top protections
- 3 back pockets
- Handles with PVC cover
- Transport shoulder strap



470 g	mm	↔ 310 ↑ 220 ↙ 140
-------	----	-------------------------

MAX 9 kg

CAPACITY 8 L

007 FLV U00070007

Tool bag (empty)

- Model in high strength Fabric
- Frontal pocket with zipper closure
- Back pocket with velcro closure
- Rigid reinforced bottom
- Internal toolholder compartments
- Handles with PVC cover

NEW RANGE 002

EXCELLENCE FOR EVERYDAY WORK.



INCLUDED



002 MA
U00020031

181
PIECES

11,5 kg	mm	460
		158
		385

Case with assortment for maintenance



002 TMA
U00020035

181
PIECES

13 kg	mm	470
		200
		370

Trolley case with assortment for maintenance

BI-COLOUR FOAM MODULES



519 M 613AEA 519 M 613CEA 519 M 285A1



519 M 127C 519 M 150AX 519 MSK6



519 M 324H 519 M 324STX 519 MSK6+692 J32



519 M 990A5B 519 M 382 519 MSK6



519 M 285A1 519 M 324H 519 M 324STX



519 M 613AEA 519 M 612CLA



519 M 276C



T-HANDLE WRENCHES

8-10-13-17 mm

495 MB

U04950628

156
PIECES



Assortment for MAINTENANCE - 4 drawers

DESCRIPTION	ITEM	PCS
Hexagonal sockets, ratchet (237 A 1/4"), accessories 1/4" and bits	519 M 613AEA	46
Hexagonal sockets, ratchet (237 A 1/2") and accessories 1/2"	519 M 613CEA	23
Combination wrenches (6-7-8-9-10-11-12-13-14-15-16-17-18-19-21-22-24 mm)	519 M 285A1	17
Pliers for circlips internal and external 15÷25 and 19÷60	519 M 127C	6
Universal pliers, adjustable pliers, cutting nippers, extra-long nose pliers, lock-grip pliers	519 M 150AX	5
Screwdrivers for slot-head and PHILLIPS® screws	519 M 324H	7
Screwdrivers for TORX® Tamper Resistant screws	519 M 324STX	8
Flat square file, half-round file, round file, square file, triangular file (second cut)	519 M 990A5B	5
Hammer for mechanics with graphite handle, mallet, pin punches, chisel and centre punch	519 M 382F	7
Assortment with bits and reversible ratchet	692 J32	32

495 MAA

U04950627

155
PIECES



Assortment for car repair - 3 drawers

DESCRIPTION	ITEM	PCS
Hexagonal sockets, ratchet (237 A 1/4"), accessories 1/4" and bits	519 M 613AEA	46
Bi-hexagonal sockets, ratchet (237 A 1/2") and accessories 1/2"	519 M 612CLA	35
Combination wrenches (6-7-8-9-10-11-12-13-14-15-16-17-18-19-21-22-24 mm)	519 M 285A1	17
Screwdrivers for slot-head and PHILLIPS® screws	519 M 324H	7
Screwdrivers for TORX® Tamper Resistant screws	519 M 324STX	8
Pliers for circlips, combination plier, long nose pliers, T-handle wrenches with hex sockets (8-10-13-17 mm), bits set with ratchet	519 M 276C	42



519 M 612CLA



519 M 613BEA 519 M 613AEA

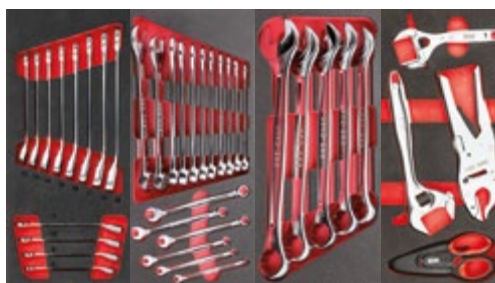

519 M 285KA 519 M 285A1 519 M 285A2 519 M 294B

301
PIECES



495 MC

U04950632

Assortment for MAINTENANCE - 4 drawers



519 M 324H 519 M 324STX 519 M 280HG 519 M 280N1



519 M 127C 519 M 150AX 519 M 382F 519 M 990A5MD

PLASTIC TRAYS



519/613AEA 519/613CEA 519 SK692V



519/285A1 519/150AX 519 SK692V

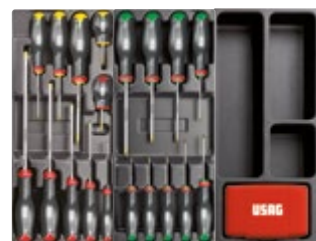

519/324H 519/324TX 519 SK692V + 692 J32



519 SK692V 519/990A1 519/382F



519/613AEA 519/613CEA 519 SK692V + 692 J32



519/324H 519/285A1 519/150AX



T-HANDLE WRENCHES
7-8-10-12-13-17 mm

495 PM
U04950630

157
PIECES



Assortment for MAINTENANCE - 4 drawers

DESCRIPTION	ITEM	PCS
Hexagonal sockets, ratchet (237 A 1/4"), accessories 1/4" and bits	519/613AEA	42
Hexagonal sockets, ratchet (237 A 1/2") and accessories 1/2"	519/613CEA	22
Combination wrenches (6÷24 mm) and angled keys (1,5÷10 mm)	519/285A1	25
Universal pliers, adjustable pliers, cutting nippers, extra-long nose pliers, lock-grip pliers	519/150AX	5
Screwdrivers for slot-head and PHILLIPS® screws	519/324H	10
Screwdrivers for TORX® screws	519/324TX	9
Flat square file, half-round file, round file, triangular file (second cut)	519/990A1	4
Hammers, chisels and pin punches	519/382F	8
Assortment with bits and reversible ratchet	692 J32	32

495 PA
U04950629

142
PIECES



Assortment for car repair - 2 drawers

DESCRIPTION	ITEM	PCS
Hexagonal sockets, ratchet (237 A 1/4"), accessories 1/4" and bits	519/613AEA	42
Hexagonal sockets, ratchet (237 A 1/2") and accessories 1/2"	519/613CEA	22
Screwdrivers for slot-head and PHILLIPS® screws	519/324H	10
Combination wrenches (6÷24 mm) and angled keys (1,5÷10 mm)	519/285A1	25
Universal pliers, adjustable pliers, cutting nippers, extra-long nose pliers, lock-grip pliers	519/150AX	5
T-handle wrenches with jointed hexagonal socket (7-8-10-12-13-17 mm)	276 CE	6
Assortment with Ribe bits with hole - XZN - TORX® Tamper Resistant	692 J32	32

DESCRIPTION	ITEM	PCS
Hexagonal sockets, ratchet (237 A 1/4"), accessories 1/4" and bits	519 M 613AEA	46
Hexagonal sockets, ratchet (237 A 3/8") and accessories 3/8"	519 M 613BEA	20
Hexagonal sockets, ratchet (237 A 1/2") and accessories 1/2"	519 M 612CLA	35
Reversible ratchet combination wrenches 8-9-10-11-12-13-14-15-16-17-18-19 mm	519 M 285 KA	12
Combination wrenches (6-7-8-9-10-11-12-13-14-15-16-17-18-19-21-22-24 mm)	519 M 285A1	17
Combination wrenches 27-29-30-32-34 mm	519 M 285A2	5
Adjustable wrenches, lock-grip pliers and scissor	519 M 294B	4
Screwdrivers for slot-head and PHILLIPS® screws	519 M 324H	7
Screwdrivers for TORX® Tamper Resistant screws	519 M 324STX	8
Hexagon keys with handgrip (3-4-5-6-7-8-10 mm)	519 M 280HG	7
Set of keys for TORX® screws and assortment of bits with special shapes	519 M 280N1	117
Pliers for circlips internal and external 15÷25 and 19÷60	519 M 127C	6
Universal pliers, adjustable pliers, cutting nippers, extra-long nose pliers, lock-grip pliers	519 M 150AX	5
Flat square file, half-round file, round file, square file, triangular file (second cut)	519 M 990A5B	5
Hammer for mechanics with graphite handle, mallet, pin punches, chisel and centre punch	519 M 382F	7



**CAN'T FIND YOUR
IDEAL ASSORTMENT?**

**Go now to kitplanner-gb.usag.it
and create it!**

Plastic trays



519/127N
U05190716

4
PIECES

127 N 19÷60 · 127 PN 19÷60 ·
128 N 19÷60 · 128 PN 19÷60.



519/150AX
U05190850

5
PIECES

133 AX 160 · 134 250 · 150 AX 180 ·
180 C 250 · 188 AX 160.



519/252A1
U05190821

11
PIECES

252 N 6x7-8x9-10x11-12x13-14x15-16x17-
18x19-21x23-22x24-27x29-30x32.



519/280HG
U05191860

7
PIECES

280 HG 3-4-5-6-7-8-10.



519/280HGTS
U05191861

7
PIECES

280 HGTS 3-4-5-6-7-8-10.



519/285A1
U05190785

25
PIECES

285 6-7-8-9-10-11-12-13-14-15-16-17-
18-19-22-24 280 S9 1,5÷10.



519/285B2
U05190823

4
PIECES

285 27-29-30-32.



519/285KA1
U05190788

12
PIECES

285 KA 8-9-10-11-12-13-14-15-
16-17-18-19.



519/299
U05190760

5
PIECES

299 6-7-8-10-13.



519/322H
U05190772

10
PIECES

322 0,5x3x75-0,8x4x100-1x5,5x125-
1,2x6,5x150-1,6x8x175 · 322 PH 0x75-1x100-
2x125 · 322 N 0,8x4x30 · 322 NPH 2x30.



519/324H
U05190763

10
PIECES

324 0,5x3x75-0,8x4x100-1x5,5x125-
1,2x6,5x150-1,2x8x200 · 324 PH 0x75-1x75-
2x100 · 324 N 0,8x4x35 · 324 NPH 2x35.



519/324TX
U05190764

9
PIECES

324 TX T6x50-T7x50-T8x50-T9x75 · 324 STX
T10x75-T15x75-T20x100-T25x100-T30x125.



519/382F
U05190742

8
PIECES

362 150 · 367 2x100-3x130-4x145-
5x165 · 368 4x125 · 376 35 · 382F 500.



519/613AEA 
U05190784

42
PIECES

235 1/4" EN 4-4,5-5-5,5-6-7-8-9-10-11-12-13-
14 · 236 1/4" 50-150 · 237 A 1/4" · 240 1/4" ·
241 1/4" · 243 1/4" · 692 S11 · 692 STX/S11 ·
684 1/4"-1/4".



519/613BEA 
U05190747

22
PIECES

235 3/8" E 6-7-8-9-10-11-12-13-14-15-
16-17-18-19-21-22 · 236 3/8" 125-250 ·
237 A 3/8" · 240 3/8" N · 241 3/8".



519/613CEA 
U05190750

22
PIECES

235 1/2" EN 10-11-12-13-14-15-16-
17-18-19-20-21-22-24-27-30-32 · 236
1/2" 125-250 · 237 A 1/2" · 240 1/2" N
· 241 1/2".



519/990A1
U05190825

4
PIECES

990 M PA/200 · 990 M PB/200
990 M PC/200 · 990 M PE/200.



519/960
U05190753

7
PIECES

207 A · 220 B1 · 960 · 966/20 · 974 · 978
A/200 · 981 A/3.



**Create your ideal
assortment**

*Discover the full range of
plastic modules at
usag.it or scan the QR code.*



8
PIECES **XL**

519/280T
U05190727

280 T 2-2,5-3-4-5-6-8-10.

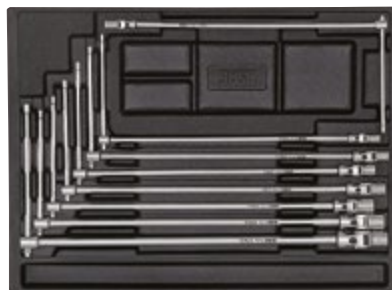

8
PIECES **XXL**

519/276
U05190725

276 CE 7-8-10-11-13-14-17-19.

Bi-colour foam modules

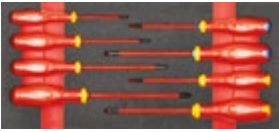

519 M 091A
U05191016 **8** PIECES
091 0,5x3x75-0,8x4x100-1x5,5x125
1,2x6,5x150 · 091 PH 1x100-2x125 · 091
PZ 1x100-2x125.

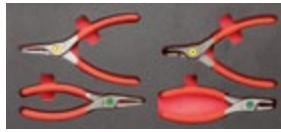

519 M 127N
U05190937 **4** PIECES
127 N 19÷60 · 127 PN 19÷60 ·
128 N 19÷60 · 128 PN 19÷60.



519 M 150AX
U05190965 **5** PIECES
133 AX 160 · 134 250 · 150 AX 180 ·
180 C 250 · 188 AX 160.

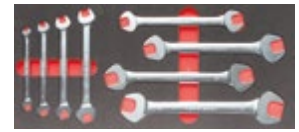

519 M 252
U05191072 **8** PIECES
252 N 6x7-8x9-10x11-12x13-14x15-
6x17-18x19-20x22.

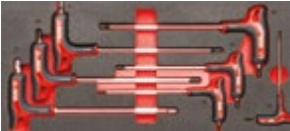

519 M 280HG
U05191945 **7** PIECES
280 HG 3-4-5-6-7-8-10.

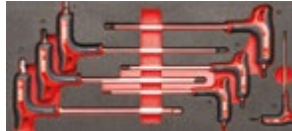

519 M 280HGTS
U05191946 **7** PIECES
280 HGTS 3-4-5-6-7-8-10.



519 M 280N1
U05191013 **117** PIECES
280 S9 1,5-2-2,5-3-4-5-6-8-10 · 280 TX/
S8C T10-T15-T20-T25-T27-T30-T40-T45
· 692 J100.



519 M 283
U05191073 **8** PIECES
283 6x7-8x9-10x11-12x13-14x15-16x17-
18x19-20x22.



519 M 285A1
U05190921 **17** PIECES
285 6-7-8-9-10-11-12-13-14-15-16-
17-18-19-21-22-24.

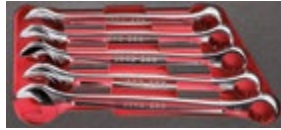

519 M 285A2
U05190943 **5** PIECES
285 27-29-30-32-34.



519 M 285KA
U05190944 **12** PIECES
285 KA 8-9-10-11-12-13-14-15-
16-17-18-19.



519 M 294B
U05191015 **4** PIECES
135 A 250 · 207 E · 294 AC · 294 AD 250.



519 M 324H
U05190910 **8** PIECES
324 0,5x3x75-0,8x4x100-1x5,5x125-
1,2x6,5x150 · 324 PH 1x100-2x125
324 D 0,6x3,5x100 324 E 1,6x8x175.

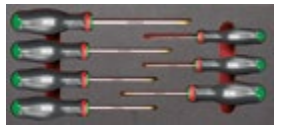

519 M 324STX
U05190911 **7** PIECES
324 STX T10x75-T15x75-T20x100-
T25x100-T27x100-T30x125-T40x150.



519 M 382F
U05190926 **7** PIECES
362 175 · 367 2x100-3x130-6x180
368 3x100 · 376 28 · 382F 500.



519 M 613AEA **46** PIECES
U05190940 237 A
235 1/4" EN 5,5-6-7-8-9-10-11-12-13-14 · 236
1/4" 50-100 · 237 A 1/4" · 240 1/4" · 241 1/4" ·
243 1/4" · 280 LTS/S9 · 684 1/4"-1/4" · 660 0,6-
1-1,6 · 660 E 3-4-5-6-8 · 660 PH 1-2-3 · 660 PZ
1-2-3 · 660 STX T15-T20-T25-T27-T30-T40.



519 M 613BEA **20** PIECES
U05190928 237 A
235 3/8" E 7-8-9-10-11-12-13-14-15-16-
17-18-19-21-22 · 236 3/8" 125-250 ·
237 A 3/8" · 240 3/8" N · 241 3/8".



519 M 613CEA **23** PIECES
U05190942 237 A
235 1/2" EN 8-10-11-12-13-14-15-16-
17-18-19-21-22-23-24-27-30-32 · 236
1/2" 125-250 · 237 A 1/2" · 240 1/2" N
· 241 1/2".



519 M 990A5MD **5** PIECES
U05191011
990 M PA/200 · 990 M PB/200 · 990 M
PC/200 · 990 M PD/200 · 990 M PE/200.



Discover the full range
of plastic modules at
usag.it or scan
the QR code.

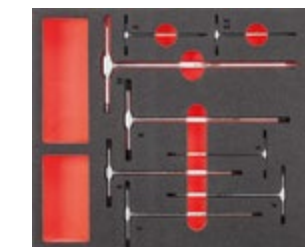

8 PIECES **XL**

519 M 280T
U05191059
280 T 2-2,5-3-4-5-6-8-10.



116 PIECES **XXL**

519 M 601S
U05191601



THE PRODUCTS

285 KA REVERSIBLE RATCHET COMBINATION WRENCHES



PIANO WIRE STEEL RING INTEGRATED

keeps the position on the nut during the operations.

Page
52



STATIC TORSION RESISTANCE
+ 30% torque compared to the value required by ISO rules 3315 because of the patented pawl..

FATIGUE RESISTANCE

Lasts twice than the other ratchets on the market because of IP51 protection.

Page
53

237 A REVERSIBLE RATCHET



443 N OIL-FILTER WRENCH

AUTOMATIC BELT CLAMPING

Page
80



THAT MAKE THE DIFFERENCE!

324 SCREWDRIVER



REINFORCED BLADE

Chrome Silicon Vanadium steel that allows the best mechanical resistance.

TOP PERFORMANCE TIP

Zinc finish. Perfect shape. Treatment against corrosion.

Page
49



TOP-LEVEL CUTTING

Can cut up to 2 mm piano wire with 30% less effort in comparison to the maximum value stated on the European rules ISO5749 (cutting nippers) - ISO5746 (pliers).



150 AX COMBINATION PLIERS



Page
54

280 T T-KEYS



GUARANTEED SAFETY

+ 30% resistance to torsion compared to ISO 2936 rules. When the breaking torque is reached, the key will deform without breaking.

Page
51



285 COMBINATION WRENCH



TOP PERFORMANCE

Resistance to static torsion of ring and open end: + 50% respect to ISO rules 1711-1.

Page
52



207 E SCISSORS FOR ELECTRICIANS



THE ONLY ONE WITH INTEGRAL STAINLESS STEEL STRUCTURE

Flexural strenght 180 Kg.

Page
66





POWER ASSIST SCREWDRIVER 324 XP SPEED OF THE BATTERY, ACCURACY OF YOUR HAND



High resistance nylon



EN 60529



Bits holding elastics



324 XP/B16
U03240801

16
PIECES

Bag with power assist screwdriver and bits

- High resistance nylon bag with belt hook
- Bits holder elastics and USB-C cable pocket

POWER ASSIST SCREWDRIVER



300 RPM
0,9 Nm

ITS SPEED
Works with 300 rpm speed coming from the electric engine.

YOUR ACCURACY
Close the tightening with the accuracy of a standard screwdriver.

10 Nm



YouTube



RATCHET SYSTEM



333 K/SH8
U03330142

COMBIDRIVE set with bits

- Delivered with 6 different bits 1/4"

DESCRIPTION	ITEM/SIZE	PCS
COMBIDRIVE handgrip with 3 functions	333 K	1
COMBIDRIVE magnetic bit-holder	333 1/4 MG	1
Bits for slot-head screws -1/4"	660/0,6x4,5-1x5,5	2
Bits for PHILLIPS® screws -1/4"	660 PH 1-2	2
Bits for hex socket screws -1/4"	660 E 3-4	2



RATCHET SYSTEM



USAG 660 bits not included

10
PIECES



333 K/SB10
U03330143

COMBIDRIVE set in nylon bag

- Delivered with 8 different blades
- Nylon bag with belt hook

DESCRIPTION	ITEM/SIZE	PCS
COMBIDRIVE handgrip with 3 functions	333 K	1
COMBIDRIVE magnetic bit-holder	333 1/4 MG	1
Reversible COMBIDRIVE blades for slot-head screws	333 1,0x3,5-0,8x4/1x5,5-1,2x6,5	2
Reversible COMBIDRIVE blades for PHILLIPS® screws	333 PH 0-1/2-3	2
Reversible COMBIDRIVE blades for TORX® screws	333 TX T8-T9	2
Reversible COMBIDRIVE blades for TORX® screws	333 STX T10-T15/T20-T25/T30-T40	4



SCREWDRIVERS 324



YouTube



8
PIECES

324 SH8

U03240650

Set of 8 screwdrivers for slot-head and PHILLIPS® screws

- 324 D/0,4x2,5x50.
- 324/0,5x3x75-0,8x4x100-1x5,5x125-1,2x6,5x150.
- 324 PH/0x75-1x75-2x100.



12
PIECES

324 SH12

U03240651

Set of 12 screwdrivers for slot-head, PHILLIPS® and POZIDRIV® -SUPADRIV® screws

- 324 D/0,4x2,5x50.
- 324/0,5x3x75-0,8x4x100-1x5,5x125-1,2x6,5x150.
- 324 N/1x5,5x35.
- 324 PH/0x75-1x75-2x100.
- 324 NPH/2x35.
- 324 PZ/1x75-2x100.



7
PIECES

324 STX/S7

U03240662

Set of 7 screwdrivers for TORX® Tamper Resistant screws

- 324 STX T10x75-T15x75-T20x100-T25x100-T27x100-T30x125-T40x150.

SCREWDRIVERS 091 1000V INSULATION - EN 60900.



5
PIECES

091 D/SH5

U00910119

Set of 5 SLIM screwdrivers for slot-head and PHILLIPS® screws - 1000 V

- 091 D/0,6x3,5x100-0,8x4x100-1x5,5x125.
- 091 DPH/1x100-2x125.



5
PIECES

091 SH5

U00910100

Set of 5 screwdrivers for slot-head and PHILLIPS® screws - 1000 V

- 091/0,5x3x75-0,8x4x100-1x5,5x125.
- 091 PH/1x100-2x125.



8
PIECES

091 SH8

U00910106

Set of 8 screwdrivers for slot-head and PHILLIPS®, POZIDRIV® - SUPADRIV® screws - 1000 V

- 091/0,5x3x75-0,8x4x100-1x5,5x125-1,2x6,5x150.
- 091 PH/1x100-2x125.
- 091 PZ/1x100-2x125.

SLIM

Hexagonal keys and bits



7
PIECES

322 SH7

U03220254

Set of 7 screwdrivers for slot-head and PHILLIPS® screws

- 322//0,4x2x50-0,5x3x75-0,8x4x100-1,5,5x100-1,2x6,5x150.
- 322 PH/1x100-2x125.



10
PIECES

322 SH10

U03220255

Set of 10 screwdrivers for slot-head, PHILLIPS® and POZIDRIV® screws

- 322//0,4x2x50-0,5x3x75-0,8x4x100-1x5,5x100-1,2x6,5x150.
- 322 PH/0x75-1x100-2x125.
- 322 PZ/1x100-2x125



210 MM
LENGTH



YouTube

1/4"



1/4"



280 TQ

U02800800

T-key bit holder

- Double magnetic bit-holder 1/4"
- Maximum capacity of the bit-holder: 6 mm hexagonal bit or T40 Torx bit
- Single end with 1/4" sockets square drive
- Special Chrome Vanadium steel
- Chrome plated finish

Compact supports with quick extraction system



WATCH
THE VIDEO



YouTube

9
PIECES

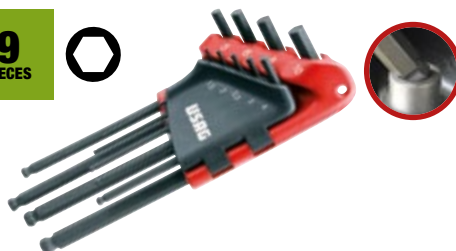

280 LTS/S9

U02800084

Set of 9 long angled hexagon keys with spherical head

- 280 LTS/1,5-2-2,5-3-4-5-6-8-10 mm.

8
PIECES



280 LTSTX/S8

U02800078

Set of 8 long angled keys with spherical head for TORX® screws

- 280 LTSTX/T10-T15-T20-T25-T27-T30-T40-T45.

9
PIECES



280 XLTS/S9

U02800184

Set of 9 long hexagon keys with spherical head

- 280 XLTS/1,5-2-2,5-3-4-5-6-8-10 mm.

EXTRA LONG MODEL
+30% OF THE STANDARD 280 LTS

Hexagonal keys and bits



YouTube



7
PIECES



280 T/SE7
U02800903

Set of 7 T-handle hexagon keys
• 280 T/2-2,5-3-4-5-6-8 mm.



6
PIECES



280 TTS/SE6
U02800760

Set of 6 T-handle hexagon keys with spherical head
• 280 TTS/2,5-3-4-5-6-8 mm.



Spherical head

6
PIECES



280 TK/SE6
U02800020

Set of 6 T-handle hexagon keys with sliding bar
• 280 TK/2,5-3-4-5-6-8 mm.

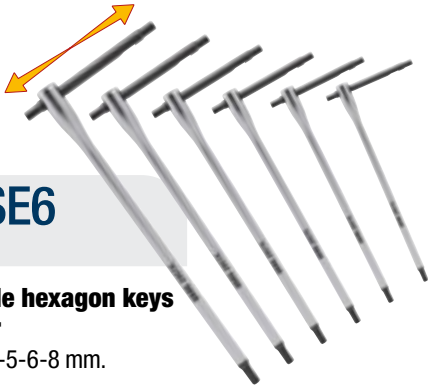

Sliding bar

6
PIECES



280 HG/SE6
U02801460

Set of 6 angled hexagon keys with bimaterial handgrip
• 280 HG/2,5-3-4-5-6-8 mm.



6
PIECES



280 HGTS/SE6
U02801463

Set of 6 angled hexagon keys with spherical head and bimaterial handgrip
• 280 HGTS/2,5-3-4-5-6-8 mm.



Spherical head



6
PIECES



280 HATX/SE6
U02800464

Set of 6 angled keys with handgrip for TORX® screws
• 280 HATX/T8-T10-T15-T20-T25-T30.



XGRIP



DISCOVER THE X-GRIP RANGE

Go to page 6

Wrenches



YouTube

8
PIECES

8÷19 mm

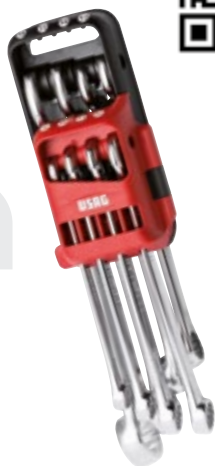

285 DS8

U02850863

Set of 8 combination wrenches

- 285/8-10-11-12-13-14-17-19 mm.
- Supplied with plastic holder

12
PIECES

7÷19 mm



285 DS12

U02850864

Set of 12 combination wrenches

- 285/7-8-10-11-12-13-14-15-16-17-18-19 mm.
- Supplied with plastic holder

26
PIECES

6÷32 mm



285 SE26

U02850861

Set of 26 combination wrenches

- 285/6-7-8-9-10-11-12-13-14-15-16-17-18-19-20-21-22-23-24-25-26-27-28-29-30-32 mm.

5
PIECES

8÷19 mm



285 KA/SE5

U02856074

Set of 5 reversible ratchet combination wrenches with locking ring

- 285 KA/8-10-13-17-19 mm.



YouTube

8
PIECES

8÷19 mm

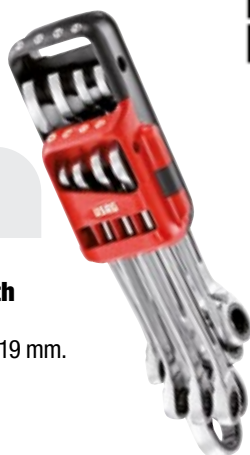

285 KA/DS8

U02856058

Set of 8 reversible ratchet combination wrenches with locking ring

- 285 KA/8-10-11-12-13-14-17-19 mm.
- Supplied with plastic holder



12
PIECES

7÷19 mm



285 KA/DS12

U02856062

Set of 12 reversible ratchet combination wrenches with locking ring

- 285 KA/7-8-10-11-12-13-14-15-16-17-18-19 mm.
- Supplied with plastic holder



XGRIP



DISCOVER THE X-GRIP RANGE

Go to page 6



5
PIECES



8÷19 mm

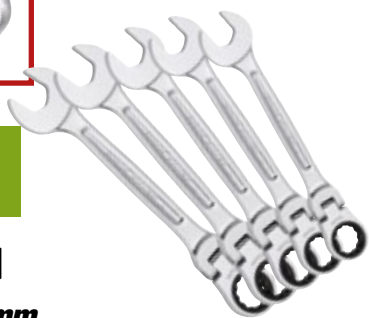

285 KF/SE5

U02856160

Set of 5 hinged jointed reversible ratchet combination wrenches

- 285 KF/8-10-13-17-19 mm.



8
PIECES



8÷19 mm



285 KF/DS8

U02856158

Set of 8 hinged jointed ratchet combination wrenches

- 285 KF/8-10-11-12-13-14-17-19 mm.
- Fornita con supporto in plastica.

8
PIECES



6÷22 mm



252 N/SR8

U02520862

Set of 8 double ended open jaw wrenches

- 252 N/6x7-8x9-10x11-12x13-14x15-16x17-18x19-20x22 mm.



UNI 6743



7÷19 mm

8
PIECES

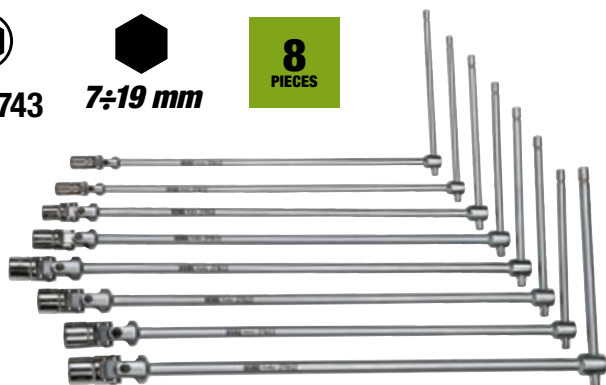

276 CE/SE8

U02760484

Set of 8 T-handle wrenches with jointed hexagonal socket

- 276 CE/7-8-10-12-13-14-17-19 mm.

ARTICULATED JOINT

- Friction-spring to allow presetting of the socket at the desired angle
- Socket and joint are fixed with a riveted steel pin for great stability.



23
PIECES

1 1/2"



YouTube



19
PIECES

1 1/4"

606 1/2" EA

U06060302



3 kg | 60 mm | 330 | 60 | 215

Assortment with hexagonal sockets in ABS case

- High resistance ABS case with quick closing system.

DESCRIPTION	ITEM/SIZE	PCS
Hexagonal sockets	235 1/2 EN 8-9-10-11-12-13-14-15-16-17-18-19-21-22-23-24-27-30-32	19
Extensions	236 1/2 125-250	2
Universal joint	241 1/2	1
Reversible ratchet with sealed mechanism (certified IP51)	237 A 1/2	1

606 1/4" EA

U06060101



1 kg | 60 mm | 210 | 60 | 130

Assortment with hexagonal sockets in ABS case

- High resistance ABS case with quick closing system.

DESCRIPTION	ITEM/SIZE	PCS
Hexagonal sockets	235 1/4 EN 4-4,5-5-5,5-6-7-8-9-10-11-12-13-14	13
Extensions	236 1/4 50-100	2
Universal joint	241 1/4	1
T-handle with sliding square drive	240 1/4	1
Spinner with handle	243 1/4	1
Reversible ratchet with sealed mechanism (certified IP51)	237 A 1/4	1

Pliers



YouTube



150 AX/SE3

U01500201

3
PIECES

Assortment with combination pliers, extra-long half-round nose pliers and cutting nippers

- Combination pliers 150 AX 180
- Half-round extra-long nose pliers with straight jaws 133 AX 160
- Diagonal cutting nippers 188 AX 160



1000 V

085 EX/SE3

U00850121

3
PIECES

Assortment with combination pliers, half-round nose pliers with straight jaws and diagonal cutting nippers - 1000 V

- Half-round extra-long nose pliers with straight jaws 081 EX 160
- Combination pliers 085 EX 180
- Diagonal cutting nippers 087 EX 160



MAX.
CAPACITY
80 mm



135 B

U01350510

Lock-grip rack-type pliers with long jaws

- Forged jaws
- Toothing designed for a perfect grip even on round surfaces
- Patented opening system integrated in the handles
- Roller grip adjustment integrated in the handle
- 5-positions rack

MAX.
CAPACITY
135 mm



135 C

U01350530

Lock-grip rack-type pliers with long jaws

- Forged jaws
- Toothing designed for a perfect grip even on round surfaces
- Patented opening system integrated in the handles
- Roller grip adjustment integrated in the handle
- 5-positions rack

FLUSH CUT



186 C

Diagonal cutting nippers with flush cutting edge for plastics

- Rounded thinned jaws
- Spring-action
- Handles sheathed in PVC

For plastics



FLUSH CUT BENT
AT 45°



187 C

U01870001

Diagonal cutting nipper bent at 45° with flush cutting edge for plastics

- Rounded thinned jaws
- Spring-action
- Handles sheathed in PVC
- Special Chrome Vanadium steel
- Burnished finish with polished head

CODE L

U01860060 150 mm 22 mm

U01860061 180 mm 27 mm

**FOR THE SMOOTH, FLUSH CUTTING OF SPRUE
AS ARISES DURING INJECTION MOULDING**

NEW AUTOMATIC SELF-LOCKING PLIERS



Ensures optimal grip on both flat and round objects



134 K 150
Round MAX | Flat MAX
Ø 25 mm | 20 mm

134 K 250
Round MAX | Flat MAX
Ø 38 mm | 30 mm



ALWAYS READY, ZERO ADJUSTMENTS

Patented automatic adjustment function: the pliers automatically adapt to the thickness of the workpiece

135 K
Round MAX | Flat MAX
Ø 25 mm | 20 mm



134 K

Automatic self-locking pliers with concave jaws

CODE	L	OPENING
U01340150	150 mm	31 mm
U01340250	250 mm	48 mm



135 K

U01350175

Automatic locking pliers with long jaws

HIGH-LEVERAGE DIAGONAL CUTTER

20% LESS EFFORT COMPARED TO A STANDARD DIAGONAL CUTTER

MAX. CUT
Ø 3 MM



OFFSET PIVOT

Increases leverage effect, significantly reducing the effort required for cutting

189 G
U01890200

ISO 5746

High-leverage diagonal cutter with offset pivot

- Secure grip on the wire during cutting, thanks to the jaw design
- Perfect for both demanding cuts and repetitive cutting tasks on smaller diameters
- Integrated wire gripping system at the back of the head
- Ergonomic bi-material handles
- Clear-coated finish



HOLE FOR PULLING WIRE

Pliers with straight nose

127 N AND 128 N RANGE

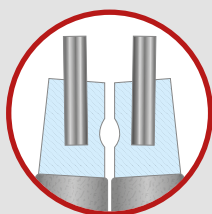

MAXIMUM RESISTANCE

Spring steel tips inserted into the nose.

127 C AND 128 C RANGE

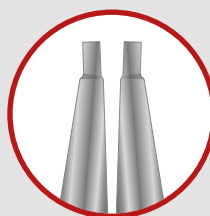

MAXIMUM ACCESSIBILITY

Nose and tip in a single body.



4
PIECES



127 N/SE4S

U01270046

10÷25 mm

Set of 4 pliers for circlips

- Pliers for internal circlips **127 N** 12÷25, **127 PN** 12÷25, pliers for external circlips **128 N** 10÷25, **128 PN** 10÷25



4
PIECES



127 C/SE4S

U01270045

10÷25 mm

Set of 4 pliers for circlips

- Pliers for internal circlips **127 C** 12÷25, **127 CP** 12÷25, pliers for external circlips **128 C** 10÷25, **128 CP** 10÷25

127 N/SE4

U01279000P

19÷60 mm

Set of 4 pliers for circlips

- Pliers for internal circlips **127 N** 19-60, **127 PN** 19-60, pliers for external circlips **128 N** 19-60, **128 PN** 19-60

127 C/SE4

U01270040

19÷60 mm

Set of 4 pliers for circlips

- Pliers for internal circlips **127 C** 19-60, **127 CP** 19-60, pliers for external circlips **128 C** 19-60, **128 CP** 19-60

RACK-TYPE PLIERS



REMOVABLE AND INTERCHANGEABLE TIPS,
fixed by a 5 mm hexagon

RACK MECHANISM
that allows to remove and install circlips with a big a diameter without effort and more precision



127 M
U01270051

Rack-type plier with straight nose for internal circlips with big dimensions



127 MP
U01270050

Rack-type plier with nose bent at 45° for internal circlips with big dimensions

128 M
U01280051

Rack-type plier with straight nose for external circlips with big dimensions

128 MP
U01280050

Rack-type plier with nose bent at 45° for external circlips with big dimensions

E-TYPE CIRCLIP TOOL KIT

5
PIECES



126 E
U01260001

E-type circlip tool kit

INTERCHANGEABLE BLADES

INSERT
mounting side

RELEASE
dismounting side



6-7-8-9 mm

AUTOMATIC ADJUSTABLE PLIERS 181 AX PERFECT GRIP, NO ADJUSTMENT REQUIRED.

60 mm MAX
OPENING

**JAWS WITH
HARDENED TEETH**

for a secure and long-lasting grip

ONE-HANDED AUTOMATIC ADJUSTMENT

Squeeze the handles and it adapts to the shape and size of the component to be operated.

**INTEGRATED LOCKING
MECHANISM**

New

181 AX
U01810250

Automatic adjusting
multi-grip pliers

New

**ERGONOMIC
BIMATERIAL
GRIP**

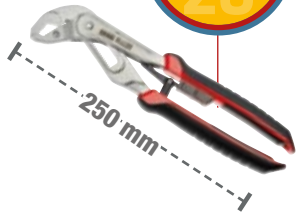

ADJUSTABLE PLIERS 180 AX WITH QUICK LOCKING SYSTEM.

**JAWS WITH
HARDENED TEETH**

for a secure and
durable grip

**QUICK LOCKING
SYSTEM**

without pressing the button.

New

180 AX

Semi-automatic adjustable pliers

ITEM	CODE	L	OPENING
180 AX 180	U01800120	180 mm	40 mm
180 AX 250	U01800121	250 mm	60 mm
180 CX 300	U01800222	300 mm	76 mm

PVC handles for the
300 mm model.

without pressing the button.



New

**ERGONOMIC
BIMATERIAL
GRIP**





YouTube

PLIER AND WRENCH IN THE SAME TOOL



174 CX

Adjustable plier wrench

CODE	L	OPENING
U01740000	180 mm	43 mm
U01740001	250 mm	58 mm
U01740002	300 mm	73 mm



QUICK ADJUST CLOSING
without pushing the button.

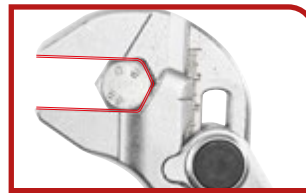

PARALLEL JAWS
Internal design that fits perfectly the hexagon.

LARGE OPENING CAPACITY +20%



YouTube

294 AD

Adjustable wrenches with quick adjustment

- Quick adjustment by pulling back the roll
- Large capacity: opening +20% compared to the standard
- Double graduated scale: millimetres and inches
- Head angled at 22°
- Steel roll
- Hanging hole
- Chrome plated finish

CODE	L	OPENING
U02940011	110 mm - 4"	17 mm
U02940012	150 mm - 6"	23 mm
U02940013	200 mm - 8"	33 mm
U02940014	250 mm - 10"	38 mm
U02940015	300 mm - 12"	41 mm
U02940016	380 mm - 15"	50 mm
U02940017	460 mm - 18"	63 mm



**QUICK ADJUSTMENT
BY PULLING BACK THE ROLL**
**PRECISE REGULATION
BY ROTATING THE ROLL**



294 AC

U02940010

Short adjustable wrench

- Length reduced of 46% compared to a standard wrench
- Same jaw opening of a 12" wrench
- Lightweight and compact for optimum accessibility
- Regulation by steel roll
- Scale in millimeters on the wrench head
- Chrome plated finish



**LENGTH REDUCED OF
46% COMPARED TO A
STANDARD WRENCH**

Ratchets and sockets



YouTube



MINI TIGHTENING RANGE

Compact dimension.
Top performance.



31
PIECES

1/4"

350 g | mm | 120
30
60



606 1/4" SK U06060012

Assortment with bits and reversible ratchet

DESCRIPTION	ITEM/SIZE	PCS
Reversible ratchet	237 1/4" SFK	1
Bits for slot-head screws -1/4"	660 0,5x4-1x5,5	2
Bits for hex socket screws -1/4"	660 E 1,5-2-2,5-3-4-5-6-7-8	9
Bits for PHILLIPS® screws -1/4"	660 PH 1-2-3	3
Bits for POZIDRIV® - SUPADRIV® screws -1/4"	660 PZ 1-2-3	3
Socket-holder bit - 1/4"	660 Q 1/4"	1
Bits for TORX® Tamper Resistant screws -1/4"	660 STX T10-T15-T20-T25-T27-T30-T40	7
Bits for TORX® screws -1/4"	660 TX T6-T7-T8-T9	4
Magnetic bit-holder adapter - 1/4"	672 1/4" MG 100	1

610 1/4" EFK U06100001

Assortment with short hexagonal sockets and reversible ratchet in bimaterial box



YouTube



11
PIECES

1/4"

265 g | mm | 120
30
60

5,5-6-7-8-9-10-
11-12-13-14 mm



SHORT HEXAGONAL SOCKETS

They offer more accessibility also using a standard ratchet.

-50%

237 1/4" SK U02370062

Reversible ratchet with extension

- 180 ° swivel head
- Inversion system with integrated lever
- Ratchet mode: maximum accessibility with the compact head and adjustable hinge
- T-handle wrench mode: the extension (L 100 mm) becomes a crossbar and the ratchet can be used as a T-handle bit-holder



1/4"

Ratchets and sockets



17
PIECES

3/4"

612 3/4" EB
U06120017



Assortment in sheet steel box with hexagonal sockets

DESCRIPTION	ITEM/SIZE	PCS
Hexagonal sockets	235 3/4 N 22-23-24-26-27-28-30-32-36-38-41-46-50	13
Extensions	236 3/4 200-400	2
T-handle with sliding square drive	240 3/4 N	1
Reversible ratchet with sealed mechanism	237 B 3/4	1

120
THEET



612 3/4" B
U06120016



**BIHEXAGONAL
SOCKETS**

Assortment in sheet steel box with bihexagonal sockets

REDUCERS

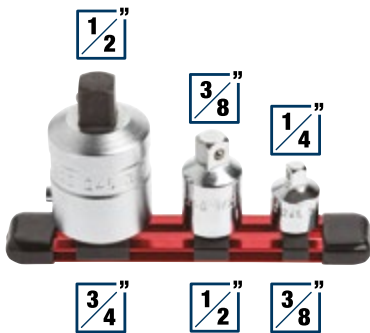

3
PIECES

246 R/S3
U02460400

Set of 3 adapter

INCREASERS



4
PIECES

247 A/S4
U02470400

Set of 4 adapter

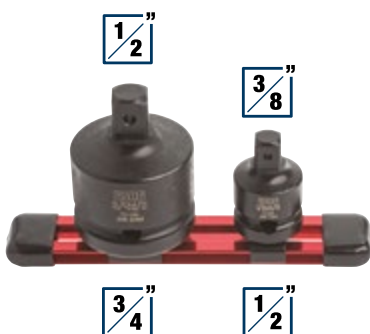

2
PIECES

246 RM/S2
U02460500

Set of 2 impact adapter

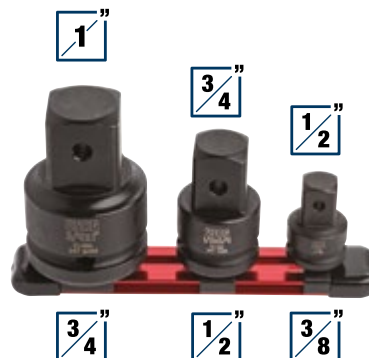

3
PIECES

247 AM/S3
U02470500

Set of 3 impact adapter

TORQUE WRENCHES 810 SA - 811 SA WITH DIRECT READ SYSTEM.



REVERSIBLE RATCHET
with 72 theet mechanism.

CLICK TORQUE SYSTEM
with compression spring.

**SEALED MECHANISM. THE
TOP OF DURABILITY.**

ADJUSTMENT RING
with automatic return

CONICAL HANDLE
in anti-slip bimaterial.



**CLOCKWISE
TIGHTENING**

ACCURACY
±4%

3/8"

1/2"

810 SA

ISO 6789

Direct read torque wrench with reversible ratchet

- Calibration certificate and REACH (SVHC) declaration included

ITEM	CODE	CAPACITY	☑	L (mm)	RESOL.
810 SA 50	U08105102	10÷50 Nm	3/8"	350	0,25
810 SA 100	U08105103	20÷100 Nm	1/2"	410	0,5
810 SA 200	U08105105	40÷200 Nm	1/2"	475	1,0
810 SA 340	U08105106	60÷340 Nm	1/2"	630	1,0



Removable
ratchet

ACCURACY
±4%

3/8"

1/2"

811 SE

ISO 6789

Direct read torque wrench with removable ratchet

- Calibration certificate and REACH (SVHC) declaration included

ITEM	CODE	CAPACITY	☑	○	L (mm)	RESOL.
811 SE 50	U08115012	10÷50 Nm	3/8"	9x12	370	0,25
811 SE 100B	U08115013	20÷100 Nm	3/8"	9x12	430	0,5
811 SE 100C	U08115015	20÷100 Nm	1/2"	9x12	430	0,5
811 SE 200	U08115017	40÷200 Nm	1/2"	14x18	510	1,0
811 SE 340	U08115018	60÷340 Nm	1/2"	14x18	665	1,0

**CLOCKWISE AND
COUNTERCLOCKWISE
TIGHTENING**

CLICK TORQUE BAR 811 LB PERFECT MATCH OF ACCURACY AND RESISTANCE

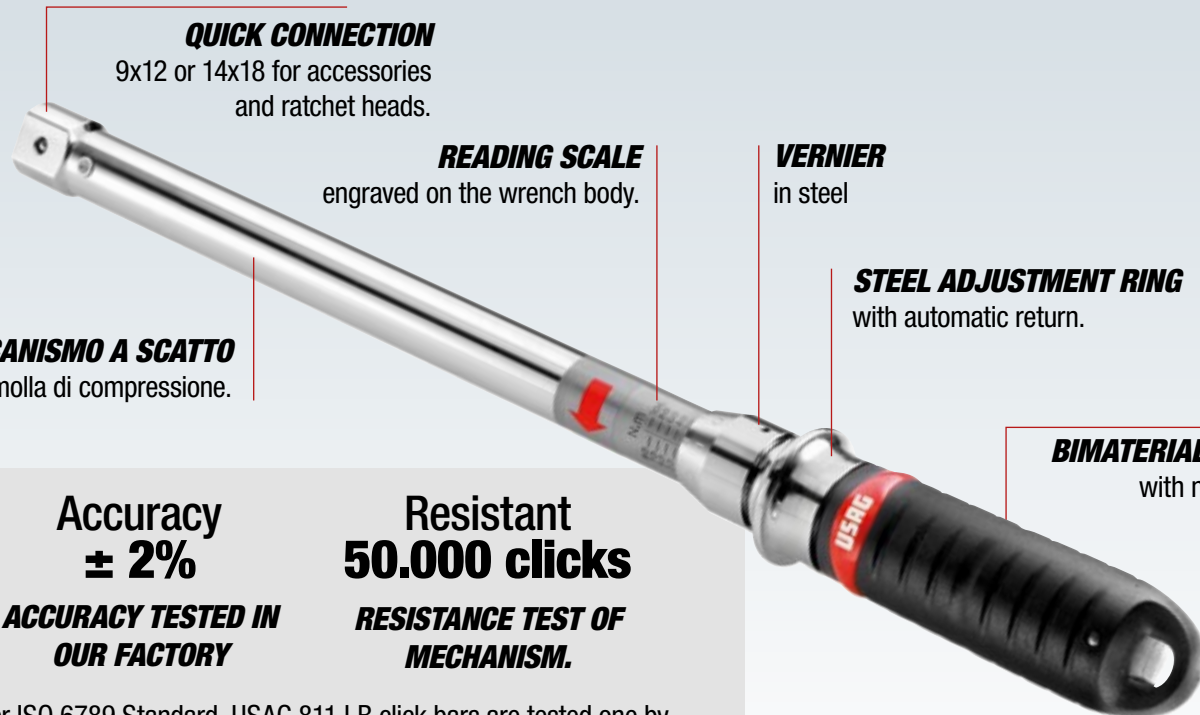

QUICK CONNECTION

9x12 or 14x18 for accessories and ratchet heads.

READING SCALE

engraved on the wrench body.

VERNIER

in steel

STEEL ADJUSTMENT RING

with automatic return.

MECCANISMO A SCATTO
con molla di compressione.

BIMATERIAL HANDLE
with no-slip grip.

Accuracy
± 2%

**ACCURACY TESTED IN
OUR FACTORY**

Resistant
50.000 clicks

**RESISTANCE TEST OF
MECHANISM.**

As per ISO 6789 Standard, USAG 811 LB click bars are tested one by one in production, before being packaged. These bars can keep an accuracy between ±2% and ±4%, even after 5,000 tightenings.



YouTube



**CLOCKWISE AND
COUNTERCLOCKWISE
TIGHTENING**

ACCURACY
±2%

811 LB

ISO 6789

Click torque bar

ITEM	CODE	CAPACITY		L	RESOL.
811 LB 50	U08115021	10÷50 Nm	<input type="checkbox"/>	357 mm	1 Nm
811 LB 100	U08115023	20÷100 Nm	<input type="checkbox"/>	437 mm	1 Nm
811 LB 200	U08115024	40÷200 Nm	<input type="checkbox"/>	515 mm	1 Nm
811 LB 350	U08115025	70÷350 Nm	<input type="checkbox"/>	725 mm	2 Nm

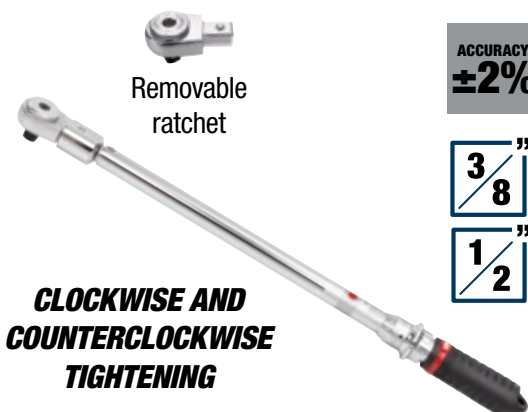

**CLOCKWISE AND
COUNTERCLOCKWISE
TIGHTENING**

Removable
ratchet

ACCURACY
±2%

3/8"

1/2"

811 LBE

ISO 6789

Click torque wrench with removable ratchet

ITEM	CODE	CAPACITY	<input checked="" type="checkbox"/>	<input type="checkbox"/>	L	RESOL.
811 LBE 50	U08115026	10÷50 Nm	<input checked="" type="checkbox"/>	<input type="checkbox"/>	407 mm	1 Nm
811 LBE 100B	U08115027	20÷100 Nm	<input checked="" type="checkbox"/>	<input type="checkbox"/>	487 mm	1 Nm
811 LBE 100C	U08115028	20÷100 Nm	<input checked="" type="checkbox"/>	<input type="checkbox"/>	487 mm	1 Nm
811 LBE 200	U08115029	40÷200 Nm	<input checked="" type="checkbox"/>	<input type="checkbox"/>	565 mm	1 Nm
811 LBE 350	U08115032	70÷350 Nm	<input checked="" type="checkbox"/>	<input type="checkbox"/>	775 mm	2 Nm

Torque Control

**CLOCKWISE
TIGHTENING**



ACCURACY
±4%

1/4"

Removable
ratchet

ACCURACY
±4%

1/4"

**CLOCKWISE AND
COUNTERCLOCKWISE
TIGHTENING**



ACCURACY
±4%

3/4"

**CLOCKWISE AND
COUNTERCLOCKWISE
TIGHTENING**



810 N

ISO 6789

Torque wrenches with reversible ratchet

- Sensible and audible alarm on reaching preset torque value
- Automatic resetting on pressure release after disengagement
- Supplied with test certificate

ITEM	CODE	CAPACITY	☑	L	RESOL.
810 N 5	U08104000	1 ÷ 5 Nm	1/4"	197 mm	0,05
810 N 25	U08104001	5 ÷ 25 Nm	1/4"	290 mm	0,05

811 NE

ISO 6789

Torque wrenches with removable reversible ratchet

- Adjustable torque model for use in combination with fittings from the 811-series
- Sensible and audible alarm on reaching preset torque value
- Automatic resetting on pressure release after disengagement
- Supplied with test certificate

ITEM	CODE	CAPACITY	☑	○	L	RESOL.
811 NE 5	U08114009	1 ÷ 5 Nm	1/4"	9x12 mm	185 mm	0,05
811 NE 25	U08114010	5 ÷ 25 Nm	1/4"	9x12 mm	300 mm	0,05

812 N

ISO 6789

Torque wrenches with reversible ratchet

- Adjustable torque model for clockwise and counterclockwise tightening by turning the ratchet 180°
- Accuracy ± 4% of the preset torque value
- Readings in Nm
- Sensible and audible alarm on reaching preset torque value
- Automatic resetting on pressure release after disengagement
- Safety block after setting torque
- Supplied in sheet steel box with test certificate

ITEM	CODE	CAPACITY	☑	○
812 N 600	U08120006	120 ÷ 600 Nm	3/4"	14x18 mm
812 N 1000	U08120010	200 ÷ 1000 Nm	3/4"	-

828 A

U08281500

Torque multiplier

1/2"

multiplication ratio

1:6,5

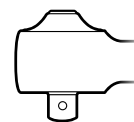

CAPACITY
1500
Nm

3/4"

Transmission ratio

1:9

828 B

U08282500

Torque multiplier

1/2"

multiplication ratio

1:12

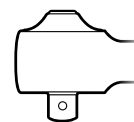

CAPACITY
2500
Nm

1"

Transmission ratio

1:16



▶ YouTube



889 RL

U08890036

LED inspection lamp



▶ YouTube



Magnetic base and
hook clamp

889 IL

U08890046

Articulated LED inspection lamp

FLEXIBLE



889 CM

U08890048

Flexible LED inspection lamp



**MOTION
DETECTION
SENSOR**



▶ YouTube

889 GR

U08890044

LED compact spotlight



889 RP

U08890045

**Compact LED rechargeable
inspection lamp**



889 SP

U08890055

LED pocket pen lamp

SCISSORS 207 E STEEL STRENGTH.



YouTube



**THE ONLY ONE WITH INTEGRAL
STAINLESS STEEL STRUCTURE**

Flexural strength 180 Kg.



207 E
U02070006

Professional scissors for electricians

**BUILT-IN WIRE
STRIPPER**



1. Stripping
2. Crimping

**CABLE CUTTER ON
BOTH BLADES**



Suitable for
multi-core cables.

**MICRO ANTI-SLIP
TOOTHING**



SCISSORS 207 D THE REFERENCE FOR ELECTRICIANS.



**HANDLES RESISTANT
TO FLEXURAL
STRENGTH UP TO 80 KG**
glass-reinforced technopolymer.

**OVERSIZED
HOLES**



207 D
U02070008

Scissors for electricians,
stainless steel blades



50 mm²

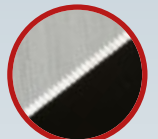

FLUID AND STRONG BLADES
with micro tothing and cable cutter.



YouTube



076 MC U00760008



Ammeter and digital multimeter TRUE RMS

- Detectable parameters: AC/DC voltage and current, resistance, continuity, diode test, temperature, capacitance, duty cycle, and frequency

TECHNICAL CHARACTERISTICS

V ~	0 ÷ 600 V
V ≡	0 ÷ 600 V
Ω	0 ÷ 60M
→	SI
•	SI
Hz	Frequency : 1 Hz-9,99 MHz
A ~	0 ÷ 600 A
A ≡	0 ÷ 600 A
%	5% ÷ 95%



076 M U00760007



Digital multimeter with TRUE RMS reading

- Detectable parameters: AC/DC voltage and current, resistance, continuity, diode test, capacitance, frequency, duty cycle, temperature, DWELL, engine speed, pulse width

TECHNICAL CHARACTERISTICS

V	6 ÷ 600V
V	600mV ÷ 600V
Ω	600 ÷ 60M
Hz	Frequency: 9,999 Hz ÷ 9,999 MHz
A	60mA ÷ 10A
A	60mA ÷ 10A
°C	-20°C ÷ 1.000°C
DWELL	90° (4 cil) ÷ 45° (8 cil)
RPM	60 ÷ 20.000 giri/min
↘	Overload protection 600 V



Ø 4 ÷ 28 mm²

163 U01630001

Multi-purpose cable sheath stripper

- For circular and longitudinal stripping of cables with external sheathing in PVC
- Trigger system (-30% effort): necessary pressure 75N
- Roller for regulating cutting depth
- Self rolling stripping blade
- Trigger stop when blade is out
- Safety blade stop
- Ergonomic plastic body
- Spare blade included
- Kit of spare blades code 872272



0,02 ÷ 10 mm²

146 A U01460003

Automatic wire strippers, straight

- Cutting and stripping functions for electrical wires
- Capacity 0,02-10 mm²/AWG 34-80
- Interchangeable jaws without tools
- Built-in wire cutter
- Precise adjustment of the stripping diameter to avoid damages
- Adjustable stripping length
- After each stripping operation, the jaw opens automatically to facilitate the extraction of the wire
- Ergonomic bimaterial handles

Maintenance

**STAINLESS
STEEL BLADE**

211 A
U02110001

Multi-purpose scissors

- Blade with micro anti-slip tothing
- Selection lever to adapt to small and big hands
- Security lever to block the blades
- Antislip bimaterial ergonomic handgrips



**STAINLESS
STEEL BLADE**

210 C
U02100003

Multi-purpose scissors

- Stainless steel blade with micro antislip tothing
- Big ergonomic bimaterial handles
- Perfect for Aluminium, cardboard, rubber, leather, moquette, etc.

**FOR
RIGHT-HANDERS**



200 S
U02000002

Hacksaw

- Steel body with anti-slip and shock resistant plastic coating
- Supplied with Cobalt blade 200 C24



056 A
U00560003

LED telescopic inspection mirror with articulated head

- Scratch-resistant glass mirror
- Protective bumper edge in plastic material
- LED to prevent shadows on the inspection area



**Ø GLASS MIRROR
55 mm**

**-20% EFFORT
COMPACT AND POWERFUL**



**ALUMINIUM
AND STEEL**

995 LA
U09950004

Straight compact hand riveter

- Compact model with the same capacity as a standard long riveter
- The internal lever system reduces operator effort
- Suitable for Aluminum and steel rivets
- 5 interchangeable heads
- Removable holder for spent nails
- Light alloy body
- Plastic handles



995 CA
U09950008

Hand riveter for blind-nut rivets

- Compact model with internal lever system that reduces operator effort
- Supplied with 4 interchangeable heads (M4-M5-M6-M8)
- To be used with aluminium and steel blind nuts (M4-M5-M6-M8) and stainless steel (M4-M5)
- Light alloy body
- Plastic handles
- Supplied in a plastic case (LxDxH: 320x175x50 mm) with blind nuts holders (not included)

**FOR BLIND-NUT
RIVETS
(not included)**



**Ø
M4 - M5
M6 - M8**

DIN 338

HSS-G

14
PIECES



988 LA/S14

U09880070

Assortment with tap and drills

- Ø drills: 2,5-3,3-4,2-5,0-6,8-8,5-10,2
- M taps: 3x0,5-4x0,7-5x0,8-6x1-8x1,25-10x1,5-12x1,75

DIN 338

HSS-G

19
PIECES



988 MA/S19

U09880073

Assortment with drills

- Ø drills: 1,0-1,5-2,0-2,5-3,0-3,5-4,0-4,5-5,0-5,5-6,0-6,5-7,0-7,5-8,0-8,5-9,0-9,5-10,0

DIN 338

HSS-G

25
PIECES



988 MA/S25

U09880074

Assortment with drills

- Ø drills: 1,0-1,5-2,0-2,5-3,0-3,5-4,0-4,5-5,0-5,5-6,0-6,5-7,0-7,5-8,0-8,5-9,0-9,5-10,0-10,5-11,0-11,5-12,0-12,5-13,0



HSS

3
PIECES



988 D/S3

U09880020

Set in sheet steel case

ITEM	Ø STEPS	Ø SHAFT	LENGTH
988 D1	4-5-6-7-8-9-10-11-12 mm	6 mm	65 mm
988 D2	4-6-8-10-12-14-16-18-20 mm	8 mm	75 mm
988 D3	4-6-8-10-12-14-16-18-20-22-24-26-28-30 mm	10 mm	100 mm

HSS

12
PIECES



988 G/S12

U09880100

Set of 10 bimetallic hole saws

- 10 pcs 988 G (Ø 19-22-25-29-35-38-44-51-57-64)
- Cutting depth Max 38 mm

HSS

10
PIECES

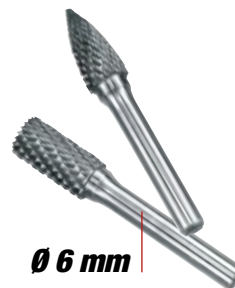

Ø 6 mm



988 E/S10

U09880062

Set of ten rotary burrs in hard metal

- 8 pcs. (Ø 10 and 12 shapes EA-EC-EF-EG)
- 2 pcs (Ø 12 shapes ED-EM)

DEAD BLOW MALLETS

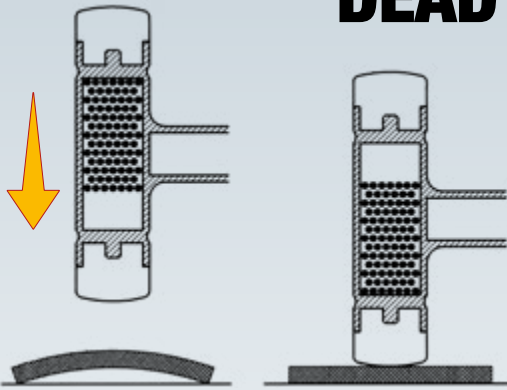

In dead blow mallets, the head is partially filled with steel balls. With each strike, they allow for rebound absorption and provide perfect balance.



STEEL BODY
with interchangeable plastic inserts.



MONOBLOCK
The head and handle are a single unit.

374 N

Non-rebound mallets

- Model with interchangeable plastic tips
- Head partially filled with metal pellets to absorb rebound
- Carbon steel body

CODE	Ø TIP	LENGTH
U03740004	35 mm	310 mm
U03740005	40 mm	315 mm
U03740006	50 mm	325 mm
U03740007	60 mm	335 mm

374 G

Non-rebound mallet monoblock

- Dead blow hammer with steel microbeads
- Steel body and handle overmolded with polyurethane
- Striking surface with Shore hardness D45 ± 5
- Ergonomic PVC handle

CODE	Ø TIP	LENGTH
U03740040	40 mm	298 mm
U03740050	50 mm	308 mm
U03740060	60 mm	316 mm



2-3-4-5-6-8 mm

367 A SE6

U03670115

6
PIECES

Set of 6 pin punches with handle

- 367/2x140-3x150-4x195-5x205-6x210-8x220 mm.
- Supplied in a high-strength fabric pouch.
- Chrome vanadium steel.
- Tipped and phosphated points for sizes 2 and 3 mm.



STEEL BODY
with interchangeable
plastic inserts.

376

UNI 7784

Mallets

- Model with interchangeable plastic tips
- Carbon steel body
- Ash wood handle

CODE	Ø TIP	LENGTH
U03760001	22 mm	250 mm
U03760002	28 mm	275 mm
U03760003	35 mm	300 mm
U03760004	42 mm	325 mm
U03760005	50 mm	350 mm
U03760006	60 mm	380 mm



Head in Carbon steel forged and subjected to differentiated heat treatment to guarantee a longer life and avoid chipping or upsetting of the striking surface.

Handle protection below the head

382

UNI 7777 DIN 6475

Hammers for mechanics

- German model with flat square head and symmetric peen
- Ash wood handle

CODE	HEAD	LENGTH
U03820002	100 g	260 mm
U03820004	200 g	280 mm
U03820006	300 g	300 mm
U03820007	400 g	310 mm
U03820008	500 g	320 mm
U03820009	600 g	330 mm
U03820010	800 g	350 mm
U03820011	1000 g	360 mm
U03820013	1500 g	380 mm
U03820014	2000 g	400 mm

2-3-4-5-6-8 mm



367 SE6

U03670081

6
PIECES

Set of 6 pin punches

- 367/2x115-3x125-4x145-5x165-6x180-8x200 mm
- Supplied in a compact fabric pouch
- Chrome Vanadium steel
- Inserted phosphatised tips for the 2 and 3 mm sizes

Extractors for broken screws

RANGE 456: FOR EXPOSED BROKEN THREADS

Can be hammered and used with impact drivers

New

1/4"
3/8"
1/2"

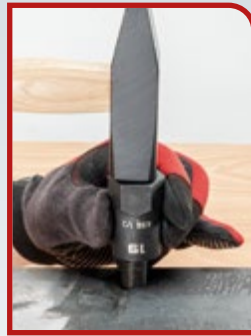

Insert



Extract



Patented removal system



SPECIAL PROFILE



MAXIMUM VERSATILITY

In addition to extracting broken screws, this extractor offers the advantage of easily adapting to components of any shape, such as round, square, or hexagonal.



RANGE 457: FOR RECESSED BROKEN THREADS

New



SPECIAL PROFILE

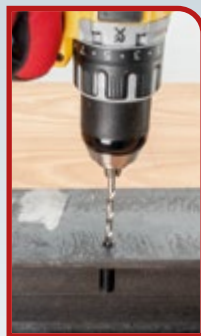

Drill

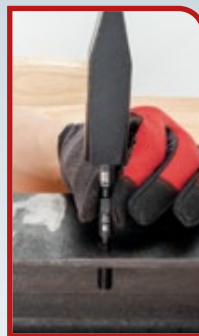

Insert

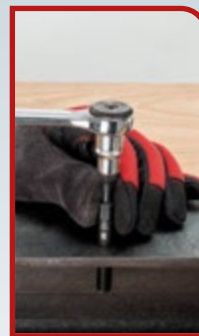

Extract



Patented removal system



New

7
PIECES



1-2-3-4-5-6-7

457 S7
U04570010

578 g | 210 mm | 60 | 130

Set of extractors for broken screws or recessed threads

Extractors for broken screws

New



9
PIECES

$\frac{1}{4}$ "

4-5-6-7-8-9-
10-11-12 mm

M3,5-M6

456 S9 1/4"

U04560101



Assortment of impact socket extractors with special profile

New



6
PIECES

$\frac{3}{8}$ "

13-14-15-16-
17-18 mm

M9

456 S6 3/8"

U04560102



Assortment of impact socket extractors with special profile

New



7
PIECES

$\frac{1}{2}$ "

19-20-21-22-
23-24-25 mm

M12

456 S7 1/2"

U04560103



Assortment of impact socket extractors with special profile

22
PIECES

New



$\frac{1}{4}$ "

4-5-6-7-8-9-
10-11-12 mm

$\frac{3}{8}$ "

13-14-15-16-
17-18 mm

$\frac{1}{2}$ "

19-20-21-22-
23-24-25 mm

M3,5-M6-
M9-M12

456 S22

U04560104



Assortment of impact socket extractors with special profile

BEARING PULLERS



474 S1
U04740001

4
PIECES

For ISO ball bearings:

6004 ÷ 6010;
6200 ÷ 6205;
6300 ÷ 6302.

Ø from 25 to 95 mm

Set in ABS case with bearing extractors



For ISO ball bearings:
6206 ÷ 6211;
6303 ÷ 6307;
6403 ÷ 6404.

Ø from 40 to 110 mm

474 S2
U04740002

4
PIECES



Set in ABS case with bearing extractors



For extracting mechanical components with internal Ø from 6.5 to 18 mm

468 NK1
U04680104

5
PIECES

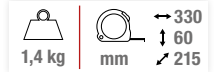

Set in ABS case with expansion extractors

ITEM	DESCRIPTION	PCS
468 C	Inside expansion pullers 1-2-3-4	4
468 ED	Slide hammer	1



For extracting mechanical components with internal Ø from 18 to 50 mm

468 NK2
U04680105

5
PIECES



Set in ABS case with expansion extractors

ITEM	DESCRIPTION	PCS
468 C	Inside expansion pullers 5-6-7-8	4
468 E1	Slide hammer	1



For extracting mechanical components with internal Ø from 8.5 to 38 mm

468 NK3
U04680106

9
PIECES



Set in ABS case with expansion extractors

ITEM	DESCRIPTION	PCS
468 C	Inside expansion pullers 2-3-4-5-6-7	6
468 D1-3	Supports for expansion pullers	2
468 F1	Adapter for slide hammers 468 D2 - D3 - E2	1



454

Outside pullers with two jaws

CODE	A	B	POWER	Hex
U04540000	65 mm	70 mm	1,5 t	13 mm
U04540010	90 mm	110 mm	3 t	17 mm
U04540020	130 mm	110 mm	3 t	17 mm
U04540030	175 mm	165 mm	4 t	17 mm
U04540040	220 mm	165 mm	4 t	17 mm
U04540050	270 mm	220 mm	5 t	21 mm
U04540060	340 mm	220 mm	5 t	21 mm



New



8÷24 mm

490 S2

U04900010

2
PIECES

Set in ABS case with nut splitters



INCLUDED IN THE PRICE

4
PIECES



451 N/S4

U04510100

Outside puller with three jaws

- Model with self-locking jaws
- Safety pin
- Working screw with 18 mm hexagonal drive
- Possibility of using with two jaws
- Carbon steel pressure screw
- Chrome Vanadium steel body
- Chrome plated and burnished finish
- Working screw M16x2
- Spare safety pins: U.306- 24J3

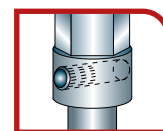

Safety pin increases working safety and preserves tool quality

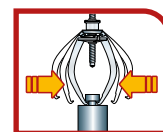

Self-locking self-centring



New

M12 - M10 - M8

1 1/2"

Hex
22 mm



459/1 S3

U04590182

3
PIECES

Set of roller pullers for studs

INTEGRATED TRANSFORMER

No external power supply.



YouTube

12 V **1200 A**



REAR CONNECTOR FOR VOLTAGE SELECTION

12 V
24 V **1400 A**
700 A



12V - 3700 A

24V - 1860 A

1613 RA12

U16130019

Professional start booster 12 V, portable

- Shockproof ABS shell
- Also suitable for sealed batteries

3500 A

Cable length
155 cm

1613 AGM12-24

U16130013

Professional start booster 12-24 V, portable

- Shockproof ABS shell
- Overvoltage protection

Cable length
155 cm



YouTube

COMPRESSION POWER

735 kg (6 bar), 1226 kg (10 bar).

447 T

U04470101

Universal pneumatic shock absorber dismantler

- Ideal for cars
- Supplied with lower brackets 447 TC1 (78÷130 mm) and 447 TC2 (105÷182 mm), vice 447 TA and universal upper clamps 447 TB1

TECHNICAL CHARACTERISTICS

Compression power	735 kg (6 bar) - 1226 kg (10 bar)
Recommended air pressure	6÷10 bar
Piston stroke	420 mm
Cylinder	Aluminium alloy and nylon resin



Adjustable pressure up to 4 BAR

12 V

10
Liters

2847/3

U28470084

Brake bleeder

- For changing, filling and bleeding the circuit of brakes on cars and industrial vehicles
- Device designed exclusively for brake fluids DOT 3, DOT 4, DOT 5.1. No LHM.

TECHNICAL CHARACTERISTICS

Operating liquid system	Peristaltic pump (no direct/liquid contact, no air pressure on liquid)
Power supply	12 V (alligators clips)
Tank capacity	10 liters
Pressure limiting device	4 bar
Elastic spiral hose	4 m (elastic)
Power cable	4 m



Supplied with:

- spare gaskets
- 1 multi-diameter cap 44-45-46 mm (2847 N11)
- 1 tank for oil recovery.

890 N U08900002



Battery tester 12V

- Allows testing of the battery health, starting system, and charging system
- Usable with 12V batteries, with capacity 100-2000 CCA, BCI, CA, MCA, IT, SAE; 100-1400 DIN, IEC; JIS 26A17-245H2
- Enables testing of standard (Lead-acid), GEL, EFB, Flat AGM, Spiral AGM, Lithium batteries
- Backlit screen
- Cable length (including clamps): 94 cm
- Reverse polarity protection
- 8 selectable languages: Italian, English, German, French, Dutch, Russian, Spanish, and Portuguese
- Battery can be tested both onboard and off the vehicle
- The tester provides 99.5% accurate results



**BATTERY TEST
CHARGING TEST
STARTING TEST**

**Cable length
94 cm**



**IDEAL TO DROP OIL INTO
THE CAR DIFFERENTIAL**

**Not suitable for fuels and
mineral oils**

**1,5
Liters**



**IDEAL FOR SUCTION AND DISPENSING OF
OIL, ANTIFREEZE, POWER STEERING OIL**



421 M U04210021

Suction gun

**9,5
Liters**



1785 B U17850005

Fluid extractor

421 P U04210020

Suction gun

**3
Liters**

**IDEAL TO DROP OIL INTO THE
CAR DIFFERENTIAL**

Working
pressure
6÷10 bar



2847 A U28470086

Vacuum brake bleeder

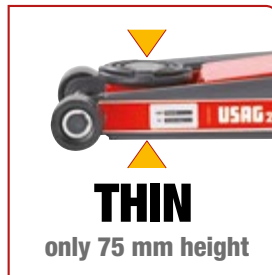

30,5 kg | 615 mm | 344

32,5 kg | 762 mm | 350

2550 A

U25500001

Hydraulic service jack 3t for cars and commercial vehicles

- Steel structure
- High capacity for use on cars, SUVs and vans
- Dual pump system to lift the car faster
- Equipped with manual descent control
- Air bleed valve, to avoid risk of over-load

3 TON | 30,5 kg

CE
3t



2550 B

U25500002

Hydraulic service jack 2t

- Steel structure
- Versatile and compact for use in narrow spaces
- Dual pump system to lift the car faster
- Equipped with lifting pedal
- Equipped with manual descent control
- Air bleed valve, to avoid risk of over-load

2 TON | 32,5 kg

CE
2t



1950 C

2
PIECES

Pair of jack stands

- Adjustable height with toothed mechanism and lever release
- Locking pin with chain
- 1950 C/3: model adjustable in 10 positions
- 1950 C/6: model adjustable in 13 positions



4,6 kg | 1.030 mm | 480 mm | 115

2000 A

U20000100

Inspection creeper

- Headrest in vinyl resistant to hydrocarbons, padded with high resistance foam rubber
- Plastic body resistant to hydrocarbons, washable



CODE	PORT.	H MAX	H MIN	DIMENSIONS	W
U19501001	3 t	427 mm	300 mm	207x188 mm	7 kg
U19501002	6 t	620 mm	400 mm	285x250 mm	14 kg

YouTube
**VIDEO
TUTORIAL**



**10
PIECES**

WHEEL LOCKING NUTS AND SCREWS REMOVER KIT

272 DS
U02720001



Kit to extract nuts and screws from alloy wheels

- Does not damage the alloy rim
- Special tungsten carbide drills capable of drilling any type of material (lubricate with cutting oil at each use)
- Super thin conical sockets to center/extract on any type of alloy wheel

REINFORCED IMPACT SOCKETS 270



DIE-CAST STEEL RING

Ensures a resistance 4 times higher than standard wheel nut sockets.



PROTECTIVE TEFLON COATING

Reduces the risk of damage when working on aluminum alloy wheels.



1 1/2"



**3
PIECES**

1 1/2"

270

Reinforced impact socket wrenches for alloy wheels with Teflon protection

CODE	●	L	Ø
U02701017	17 mm	85 mm	26 mm
U02701019	19 mm	85 mm	28 mm
U02701021	21 mm	85 mm	30 mm

270 C3
U02700160



Assortment in modular case with impact sockets for alloy wheels with Teflon protection

FAST OIL-FILTER WRENCH 443 N AUTOMATIC BELT CLAMPING.

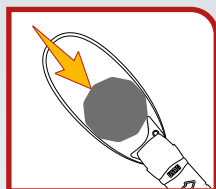

**AUTOMATIC
BELT CLAMPING**

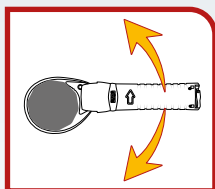

RATCHET EFFECT

Working rapidity. Possibility to work in narrow spaces.

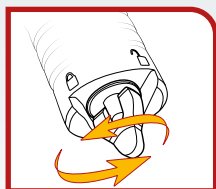

**LEVER TO INCREASE
CLAMPING POWER**



**66÷105
mm**

**443 N
U04430005**

**Fast oil-filter wrench
(cars)**



YouTube

**6
PIECES**

**3
8"**



Allows the re-tightening at the original torque (value indicated on the plastic cap)

**446 DA/SE6
U04461104**

Set of 6 cup wrenches for oil filters

- 3/8" square drive
- Steel body
- Set for Fiat, Lancia, Alfa Romeo, BMW, Renault, Volkswagen, Skoda, Audi, Seat, Mercedes
- Profile dimensions: Ø 74 mm x 14 sides - Ø 75 mm x 16 sides - Ø 86 mm x 16 sides - Ø 102 mm x 14 sides - Ø 66 mm x 18 sides - Ø 96 mm x 18 sides



Frame the QR code and download the list of applications or go to usag-tools.net

**3
8"**

**1
4"**

**30
PIECES**



7 kg mm 620
70
500

**446 S28
U04461204**

Set of 30 oil-filter cap wrenches

- Sizes of the oil-filter cap wrenches (Ø x N ° sides):
66/6 - 65/14 - 65/67 - 68/14 - 73/14 - 74/15 - 74/76 - 75/77 - 76/12 - 76/14 - 76/30 - 76/8 - 78/15 - 80/15 - 80/82 - 86/16 - 86/18 - 90/15 - 92/10 - 93/15 - 93/36 - 93/45 - 95/15 - 96/18 - 100/15 - 106/15 - 108/15 - 108/18.

Frame the QR code and download the list of applications or go to usag-tools.net



IN ALUMINIUM

446 DT/S2

U04461203

Set of two cap wrenches for oil filter covers - Japanese cars

- Reduces the risk of damage to the oil filter covers
- Can also be used for tightening with a torque wrench



2
PIECES



2 in 1

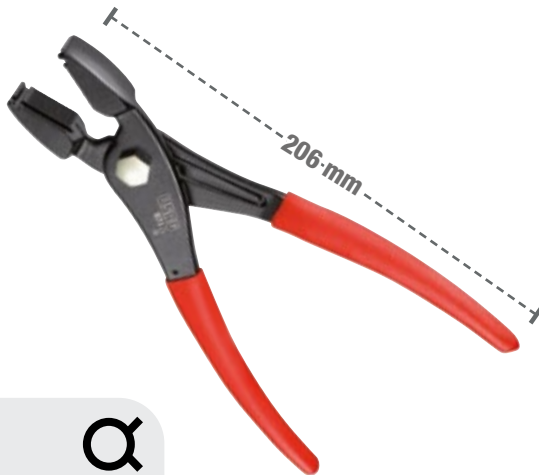

871 D

U08710001



Pliers for CORBIN clamps

- Model with frontal or side hooking
- Jaws with serrated gripping surface



3 working positions



871 C

U08719005P

CLICK spring-clips pliers

- Three-axial heads to work in any position
- To open and close CLICK spring-clips on fuel circuits, intake manifolds and hydraulic circuits

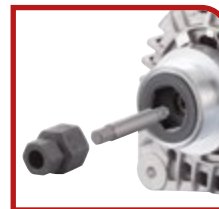

22
PIECES



1881 S22

U18810082

Set of 22 wrenches for assembling and disassembling the nuts of alternators pulleys

- Supplied in a plastic case

Connection for oil collector

16
PIECES

3/8"

263/S16

U02631400

Oil draining kit

- Magnetic sockets to hold plugs
- 1 hinged wrench 3/8"
- 2 bits \circ 8-10 mm 3/8"
- 6 bits \circ 8-10-12-13-14-17 mm 3/8"
- 6 hexagonal sockets \blacklozenge 13-14-17-18-19-21 mm 3/8"
- 1 TORX® bit \circ T45



Integrated oil collection tray



870 C

U08700006

Pliers for fuel hoses

- For petrol and diesel vehicles
- Ergonomic bimaterial handgrip

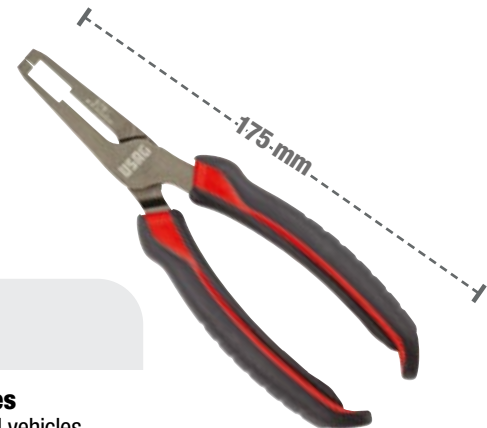



2 MODES:

- 1 250 l/min - 50°÷400°C
- 2 500 l/min - 50°÷600°C

MAX
600°

2000
WATT



Accessories included

391

U03910001

Digital heat gun

- Model with electronic checking of temperature and air volume by digital display
- Possibility to set programs: 2 heating modes and 2 air flows selectable
- Equipped with a cooling system



TECHNICAL CHARACTERISTICS

Suction cup threaded connection	M18
Sound level	78 Db
Total length	610 mm
Weight	4 Kg
Recommended air pressure	6,2 bar
Air inlet	1/4"

400 P

U04000010

Pneumatic dent puller

- Ideal to remove dents without the need to repaint
- Supplied with 3 suction cups (Ø 75-100-125 mm), in a plastic case with transport handle and closure clip
- Spare part kit with 3 suction cups: code 1004735-98

5
PIECES

To extract mouldings, fasteners, trim clips from door panels and dashboards



426 B/S5

U04260006

Set of 5 tools for plastic elements

4
PIECES

For removal of counterweights, silicone, mouldings etc.



426 C/S4

U04260007

Set of 4 multi-purpose plastic scrapers

4
PIECES

To separate timing belt cover, cylinder head engine, drive belt etc.



426 D/S4

U04260005

Set of 4 plastic separator scrapers

2
PIECES

115 CL/SE2

U01150022

Double-joint pliers with half-round jaws

- Ideal for gripping pieces and parts difficult to reach



Controlled tightening using ratchets or T-wrenches

1/2"



YouTube

814 A

Torque-angle digital adapter

- Torque and angle tightening with digital precision using conventional tools
- For CW and CCW tightening
- Measuring mode: peak/track
- Measuring unit: Nm/ft.lb/in.lb/kgcm/degree
- Visible (LED) and audible (BUZZER) indicators when preset target value is reached
- 9 presettable target values
- 50 memory slots for measured values
- Supplied in ABS case with calibration certificates
- Power supply: 2 batteries AAA (included)

CODE	CAPACITY	RESOL.
U08140003	6,8÷135 Nm	1/2" 0,1
U08140004	10÷200 Nm	1/2" 0,1
U08140005	17÷340 Nm	1/2" 0,1

Correct measurement of the angle in any position

ACCURACY
±2%



YouTube

831 A

U08310001

Digital angle meter

- Correct measurement of the angle in any position
- For CW and CCW tightening
- Accuracy: ± 2%
- Range: 0 - 360°
- Resolution: 0,1°
- Visible (LED) and audible (buzzer) indicators when preset target value is reached
- 9 presettable target values
- 50 memory slots for measured values
- Supplied in ABS case with calibration certificates
- Power supply: 2 batteries AAA (included)

9
PIECES

Two wire brushes
Ø 20mm and 25mm

885 F

U08850004

Injector cleaning kit

- Ideal for duct cleaning of injectors mounted on common rail engines



6
PIECES

1/2"

884 C/S6

U08841000

Set of six wrenches for injector pipes fittings

- For assembly and disassembly of injector pipes fittings
- Length: 98 mm
- Sizes: 12-14-16-17-18-19 mm



Air tools and accessories

COMPRESSED AIR

10 m cable
Ø 8 mm



939 C U09390003

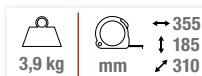

Air hose reel 8 mm

- Model with automatic hose rewind and stop device.
- Shockproof plastic body with swivel bracket for wall mounting.
- Suitable for outdoor use.
- Polyurethane/PVC hose.

TECHNICAL CHARACTERISTICS

Hose length	10 m
Internal hose diameter	8 mm
Maximum operating pressure	15 bar
Length of feeding hose	1,5 m
Output threaded male connecto	3/8"
Average air consumption	300 l/min@7bar

2006/42/CE
ISO EN 12100:2010

COMPRESSED AIR

16 m cable
Ø 10 mm



939 C1 U09390004



Air hose reel 10 mm

- Model with automatic hose rewind with holding device
- Shock resistant plastic casing with swivel bracket for attachment to wall
- Can also be used outdoors
- Polyurethane/PVC hose

TECHNICAL CHARACTERISTICS

Hose length	16 m
Internal hose diameter	10 mm
Maximum operating pressure	15 bar
Length of feeding hose	1,5 m
Output threaded male connecto	3/8"
Average air consumption	450 l/min@7bar

2006/42/CE
ISO EN 12100:2010

COMPRESSED AIR

16 m cable
Ø 12,5 mm



939 C2 U09390005



Air hose reel 12,5 mm

- Automatic hose rewind model with locking device
- Shockproof plastic body with swivel bracket for wall mounting
- Suitable for outdoor use
- Polyurethane hose/PVC

TECHNICAL CHARACTERISTICS

Hose length	16 m
Internal hose diameter	12,5 mm
Maximum operating pressure	15 bar
Length of feeding hose	1,5 m
Output threaded male connecto	3/8"
Average air consumption	800 l/min@7bar

2006/42/CE
ISO EN 12100:2010

ELECTRICITY 230V

15 m cable
3G x 1,5 mm²



939 E U09390007

 5 kg	 mm	 355 185 310
--	--	---

Cable reel

- Automatic cable rewind model with locking device
- Shockproof plastic body with swivel bracket for wall mounting
- 3G x 1.5mm² PVC cable
- Schuko plug and socket
- Rack cable locking device engageable every 50 cm

TECHNICAL CHARACTERISTICS

Hose length	15 m
Wound cable capacity	1,2 KW @230V
Unwound cable capacity	1,5 KW @230V
Protection level	IP 42

OIL AND WATER

Hose 15 m
Ø 10 mm



939 W U09390006

 15,6 kg	 mm	 550 270 505
---	--	---

Oil and water hose reel

- Automatic hose rewind model with locking device
- ABS spool and epoxy-painted steel bracket
- Black reinforced synthetic rubber hose EN857 1 SC
- Brass inlet fitting

TECHNICAL CHARACTERISTICS

Inlet fitting	3/8 F
Output threaded male connector	3/8 F girevole
Internal hose diameter	10 mm
Hose length	15 m
Maximum pressure	180 bar
Operating temperature	-15 ÷ 130 °C

Tape 20 m
Width: 4 cm



939 N U09390008

 4 kg	 mm	 350 290 160
--	--	---

Area delineation reel

- White/red striped polypropylene tape, 20 m length
- For creating temporary barriers and marking hazardous areas
- Automatic tape rewind model with locking device
- Shockproof plastic body with swivel bracket for wall mounting
- 180° adjustable bracket



Air tools and accessories

LED LIGHTING



YouTube



MAGNESIUM ALLOY CASING



943 PC1 1/2" U09430001

Magnesium impact wrench with LED - the top

TECHNICAL CHARACTERISTICS

Square drive	1/2"	Recommended air pressure	6,2 bar
Bolt capacity	M20	Sound level	94 ±3 dB(A)
Max torque	1.898 Nm	Sound power	105 ±3 dB(A)
Torque in use (Nm min-Max)	320÷460 Nm	Vibrations	6,4 m/s ²
Strokes per minute	1200	Air inlet	1/4"
Free speed	6.500 rpm	Ø internal hose	10 mm
Average air consumption	172 l/min	Weight	2,2 kg



943 PC1/C12 U09430005



12
PIECES

Assortment with hexagonal sockets and impact wrench in modular box



10-13-17-18-
19-22-24-27-
30-32 mm

MAGNESIUM ALLOY CASING



YouTube



929 PC1 1/2" U09290001

Magnesium impact wrench

TECHNICAL CHARACTERISTICS

Square drive	1/2"	Recommended air pressure	6,2 bar
Bolt capacity	M16	Sound level	93 ±3 dB(A)
Max torque	1.600 Nm	Sound power	104 ±3 dB(A)
Torque in use (Nm min-Max)	280÷440 Nm	Vibrations	6,2 m/s ²
Strokes per minute	1.300	Air inlet	1/4"
Free speed	7.000 rpm	Ø internal hose	10 mm
Average air consumption	172 l/min	Weight	2,0 kg



929 PC1/C12 U09290006



12
PIECES

Assortment with hexagonal sockets and impact wrench in modular box



10-13-17-18-
19-22-24-27-
30-32 mm



YouTube



942 PC3 1/2"

U09420012

Extra-compact impact wrench

TECHNICAL CHARACTERISTICS

Square drive	1/2"	Recommended air pressure	6,2 bar
Bolt capacity	M16	Sound level	91,1±3 dB(A)
Max torque	861 Nm	Sound power	108,1±3 dB(A)
Torque in use (Nm min-Max)	150÷220 Nm	Vibrations	9,57 m/s ²
Strokes per minute	1650	Air inlet	1/4"
Free speed	10.000 rpm	Ø internal hose	10 mm
Average air consumption	127 l/min	Weight	1,3 kg



942 PC3/C7

U09420015

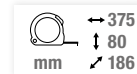

Assortment with hexagonal sockets and impact wrench in modular box

DESCRIPTION	ITEM/SIZE	PCS
Extra-compact impact wrench	942 PC3 1/2	1
Impact hexagonal sockets	235 1/2 M/ 13-17-19-21-22-24 mm	6
Lock pins	235 MCA/4	1
Safety rings	235 MDA/4	1

13-17-19-21-22-24 mm

LED LIGHTING

MAGNESIUM ALLOY CASING

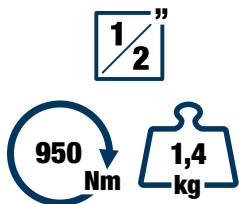

943 PC2 1/2"

U09430002

Magnesium impact wrench with LED - extra compact

TECHNICAL CHARACTERISTICS

Square drive	1/2"	Recommended air pressure	6,2 bar
Bolt capacity	M16	Sound level	95±3 dB(A)
Max torque	950 Nm	Sound power	107±3 dB(A)
Torque in use (Nm min-Max)	200÷270 Nm	Vibrations	3,9 m/s ²
Strokes per minute	1400	Air inlet	1/4"
Free speed	10.000 rpm	Ø internal hose	10 mm
Average air consumption	167 l/min	Weight	1,4 kg

ALUMINIUM BODY

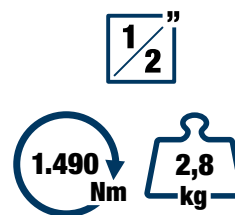

928 AC1 1/2"

U09280014

Aluminium impact wrench

TECHNICAL CHARACTERISTICS

Square drive	1/2"	Sound level	90 ±3 dB(A)
Bolt capacity	M16	Sound power	101 ±3 dB(A)
Max torque	1.490 Nm	Vibrations	5,2 m/s ²
Torque in use (Nm min-Max)	135÷380 Nm	Air inlet	1/4"
Strokes per minute	1.120	Ø internal hose	10 mm
Free speed	6.500 rpm	Weight	2,8 kg
Average air consumption	147 l/min		
Recommended air pressure	6,2 bar		

Air tools and accessories

TITANIUM ALLOY CASING

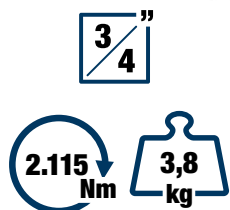

ALUMINIUM BODY

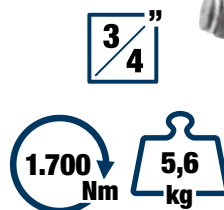

942 PD1 3/4" U09420004

Impact wrench (Titanium structure)

TECHNICAL CHARACTERISTICS			
Square drive	3/4"	Recommended air pressure	6,2 bar
Bolt capacity	M27	Sound level	97,8±3 dB(A)
Max torque	2.115 Nm	Sound power	108,8±3 dB(A)
Torque in use (Nm min-Max)	500÷800 Nm	Vibrations	5,06 m/s ²
Strokes per minute	950	Air inlet	3/8"
Free speed	5.300 rpm	Ø internal hose	10 mm
Average air consumption	200 l/min	Weight	3,8 kg

928 D1 3/4" U09280015

Aluminium impact wrench

TECHNICAL CHARACTERISTICS			
Square drive	3/4"	Recommended air pressure	6,2 bar
Bolt capacity	M24	Sound level	98,4±3 dB(A)
Max torque	1.700 Nm	Sound power	109,4±3 dB(A)
Torque in use (Nm min-Max)	500÷1.050 Nm	Vibrations	9,1 m/s ²
Strokes per minute	790	Air inlet	3/8"
Free speed	5.700 rpm	Ø internal hose	13 mm
Average air consumption	193 l/min	Weight	5,6 kg

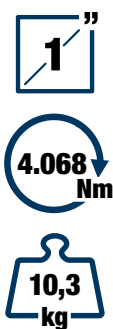

ALUMINIUM BODY

910 E1 1" U09100020

Aluminium impact wrench

TECHNICAL CHARACTERISTICS			
Square drive	1"	Recommended air pressure	6,2 bar
Bolt capacity	M33	Sound level	102 ±3 dB(A)
Max torque	4.068 Nm	Sound power	113 ±3 dB(A)
Torque in use (Nm min-Max)	850÷1.300 Nm	Vibrations	15,2 m/s ²
Strokes per minute	720	Air inlet	1/2"
Free speed	4.500 rpm	Ø internal hose	13 mm
Average air consumption	243 l/min	Weight	10,3 kg

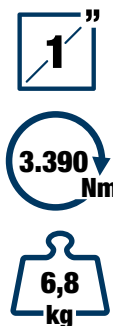

COMPOSITE MATERIAL FRAME LIGHT AND POWERFUL

weighs a 20% less than a standard model

942 PE1 1" U09420005

Impact wrench (composite material frame)

TECHNICAL CHARACTERISTICS			
Square drive	1"	Recommended air pressure	6,2 bar
Bolt capacity	M38	Sound level	100,9 ±3 dB(A)
Max torque	3.390 Nm	Sound power	111,9 ±3 dB(A)
Torque in use (Nm min-Max)	203÷1.627 Nm	Vibrations	10,6 m/s ²
Strokes per minute	900	Air inlet	1/2"
Free speed	5.000 rpm	Ø internal hose	19 mm
Average air consumption	400 l/min	Weight	6,8 kg



235 1/2" M/C16

U02359285



16
PIECES

Assortment with **IMPACT** hexagonal sockets in modular box

DESCRIPTION	ITEM/SIZE	PCS
Impact hexagonal sockets	235 1/2 M 10-12-13-14-15-16-17-18-19-21-22-24-27-30-32 mm	15
Lock pins	235 MCA/4-6	2
Safety rings	235 MDA/4-6	2
Impact extensions	236 1/2 M/125	1

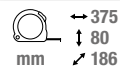

235 3/4" M/C8

U02359286



8
PIECES

Assortment with short hexagonal impact sockets

DESCRIPTION	ITEM/SIZE	PCS
Impact hexagonal sockets	235 3/4" M 21-22-24-27-30-32-36-41 mm	8



30.000 Rpm

0,3 CV
220 W

Ø 6
mm

76
l/min



922 B1

U09220001

Straight grinder - 0.3 CV (220 W)

TECHNICAL CHARACTERISTICS			
Average air consumption	76 l/min	Vibrations	2,42 m/s ²
Recommended air pressure	6,2 bar	Air inlet	1/4"
Sound level	84,8±3 dB(A)	Ø hose size	10 mm
Sound power	99,5±3 dB(A)	Weight	440 g

23.000 Rpm

0,3 CV
220 W

Ø 6
mm

76
l/min

90°



922 BP1

U09220004

90° Angle grinder - 0.3 CV (220 W)

TECHNICAL CHARACTERISTICS			
Average air consumption	76 l/min	Vibrations	4,54 m/s ²
Recommended air pressure	6,2 bar	Air inlet	1/4"
Sound level	85,9±3 dB(A)	Ø hose size	10 mm
Sound power	96,9±3 dB(A)	Weight	555 g

Air tools and accessories



IMPACT SOCKETS 235 MB



235 1/2" MB/C10

U02350530



Assortment with short hexagonal impact sockets

DESCRIPTION	ITEM/SIZE	PCS
Short impact hexagonal sockets	235 1/2" M 10-11-12-13-14-15-16-17-18-19	10

236 KE/C22

U02360900



Assortment with short hexagonal impact sockets, extension wrench and impact bits

DESCRIPTION	ITEM/SIZE	PCS
Short impact hexagonal sockets	235 1/2" MB 13-14-15-16-17-18-19	7
Bit-holder chain extension in Aluminium	236 KE 1/2"	1
Impact bits for hexagonal screws - 1/2" connection	687 E 5-6-8-10-12-14	6
Impact bits for TORX® screws - 1/2" connection	687 TX T25-T27-T30-T40-T45-T50-T55	7
Adapter for impact sockets	236 KEADP	1



YouTube

236 KE



Bit-holder chain extension in Aluminium

CODE	□	◇	L	H	📦
U02360706	1/2"	1/2"	340 mm	24 mm	1,1 kg
U02360711	1/4"	1/4"	260 mm	19 mm	300 g

COMPATIBLE WITH RATCHET OR POWER DRIVER

236 KE 1/2"

DIRECT DRIVE FOR MACHINE BITS

To be used with 1/2" drive bits (ranges 687 E and 687 TX).



SOCKETS

Insert socket adapter item 236 KEADP.



236 KE 1/4"

DIRECT DRIVE FOR BITS

To be used with 1/4" drive bits (ranges 660 and 664).



SOCKETS

Insert socket adapter 660 Q.





EN388



Protection index
3141X

**INDEX FINGER
WITH TOUCH
FUNCTION**



3000 PG

Performance Grip work gloves

- EN388 certified with protection index 3141X
- Back in padded, breathable fabric
- Palm in synthetic leather with special silicone texture for extra grip
- Fingertips fully covered in synthetic leather
- Index finger with Touch function
- Reinforcement with double layer of synthetic leather between thumb and index finger
- Thumb covered with absorbent fabric for wiping sweat
- Elastic cuff with hook-and-loop closure



**SWEAT
ABSORBING
FABRIC**

CODE	SIZE
U30001003	L
U30001004	XL

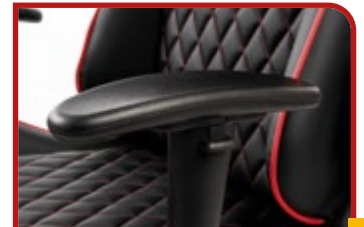

3787 A
U37870001G

Racing chair

- Material: PVC leather with molded foam padding
- Nylon base with pivoting PU wheels, diameter 60 mm
- Class 4 gas piston
- Backrest height from seat: 82 cm
- Seat dimensions: 50x53 cm
- Seat height from floor: 48-56 cm
- Total chair height: 128-136 cm

REVERSIBLE RATCHET 237 JS

LOW-PROFILE HEAD: IDEAL FOR ACCESS IN TIGHT SPACES



INCLUDED IN ALL KITS



700 kg



6
DRAWERS

3
MODULES



265
PIECES

MAINTENANCE ASSORTMENT



515 J6SM
U05150636

RAL 3020

RAL 9005

JUST roller cabinet with MAINTENANCE assortment - 3 drawers

515 J6SV
U05150106

RAL 3020

RAL 9005

JUST roller cabinet (empty)

DESCRIPTION	ITEM	PCS
Adjustable plier, chisel, pin punch, hammer, scissor, assortment with bits, plier for circlips, universal plier, hex keys, cutting nipper, mallet	519 M 150A	122
Screwdrivers for slotted screws, PHILLIPS® screwdrivers, screwdrivers for TORX® screws, screwdrivers for POZIDRIV® cross-head screws	519 M 320	27
Combination wrenches, sockets, ratchet and accessories	519 M 601S	116



515

- High-strength ABS worktop with 15 mm anti-fall edge
- Usable worktop size: 560x460 mm
- Dual transport handle for greater maneuverability
- Oil-resistant rubber mats inside the drawers
- Centralized locking safety system
- Supplied with bottle holder system, positionable on the right or left (spare part code SER.SBR2)
- Oil-resistant rubber wheels (Ø 125 mm): two fixed and two swivel (one with brake)
- Supplied with wheels already assembled to the structure
- Internal drawer dimensions:
 - 3 drawers 570x420x60 mm.
 - 2 drawers 570x420x130 mm.
 - 1 drawer 570x420x270 mm.

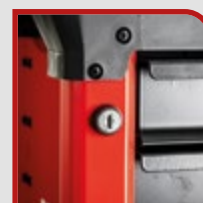

MAINTENANCE ASSORTMENT

Configuration without accessories



New

STEEL

Steel top
2.175 mm - 516 AG/2



265
PIECES



516 SA/STBA
U05160316

RAL 9005

212 kg | 2.175 mm | 2.000 mm | 650

Workshop furniture with steel top



New



116
PIECES



504 SRJM
U05041601

RAL 3020

32 kg | 901 mm | 849 mm | 452

JUST Multi-purpose roller cabinet with Maintenance assortment - 1 drawer

DESCRIPTION	ITEM	PCS
Combination wrenches, sockets, ratchet and accessories	519 M 601S	116

1
DRAWER

3
MODULES



002 JSM
U00020021

181
PIECES

Case with assortment for maintenance

11 kg | mm | 460 | 158 | 385



002 JTMS
U00020025

181
PIECES

Trolley case with assortment for maintenance.



1/4"

1/2"

8 kg | mm | 415 | 92 | 283



601 1/4-1/2" JS100
U06010031

100
PIECES

Assortment with hexagonal sockets and bits in modular box



The boxes are modular with USAG roller cabinet drawers





New

82
PIECES



1/4" 1/2"

7 kg | 415 mm | 92 | 283



601 1/4-1/2" JS82
U06010030

Assortment with hexagonal sockets and combination wrenches in modular box

The boxes are modular with USAG roller cabinet drawers



New

41
PIECES



1/2"

7 kg | 415 mm | 92 | 283

601 1/2" JS41
U06010024

Assortment with hexagonal sockets and bits in modular box

The boxes are modular with USAG roller cabinet drawers





22
PIECES

1/2"

New



601 1/2" JS22

U06010023

Assortment with hexagonal sockets in modular box

The boxes are modular with USAG roller cabinet drawers



4 kg | mm | 375
80
186



34
PIECES

1/4"

New



The boxes are modular with USAG roller cabinet drawers

601 1/4" JS34

U06010021

Assortment with hexagonal sockets and bits in modular box



1 kg | mm | 190
78
165



16
PIECES

1/4" 1/2"

New



The boxes are modular with USAG roller cabinet drawers

601 1/4-1/2" JTXS16

U06010029

Assortment with TORX® sockets in modular box



1 kg | mm | 190
58
138

TORQUE WRENCHES 810 J

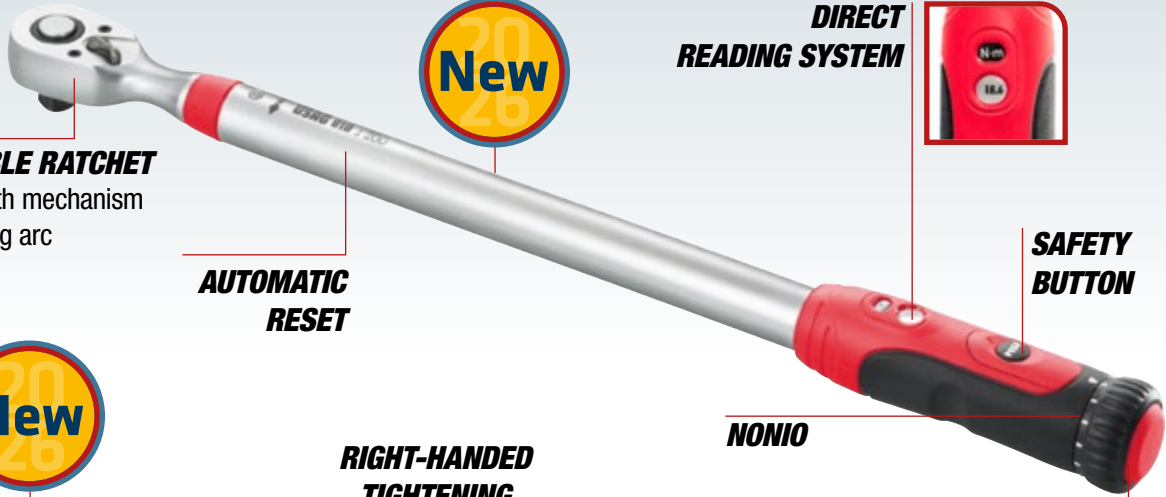

REVERSIBLE RATCHET
with 72-tooth mechanism
and 5° swing arc

**AUTOMATIC
RESET**

New

**DIRECT
READING SYSTEM**



**SAFETY
BUTTON**

NONIO

**RIGHT-HANDED
TIGHTENING**

**ADJUSTMENT
KNOB**

New

**ACCURACY
±4%**

810 J

ISO 6789

Direct-reading torque wrenches with reversible ratchet

- Includes declaration of conformity and REACH statement

ITEM	CODE	CAPACITY	☑	L (mm)	RESOL.
810 J 5-25	U08100025	5÷25 Nm	1/4"	323	0,1 Nm
810 J 10-50	U08100050	10÷50 Nm	3/8"	400	0,5 Nm
810 J 20-100	U08100100	20÷100 Nm	1/2"	400	0,5 Nm
810 J 40-200	U08100200	40÷200 Nm	1/2"	517	0,5 Nm
810 J 60-340	U08100340	60÷340 Nm	1/2"	620	1 Nm
810 J 150-750	U08100750	150÷750 Nm	3/4"	1200	2,5 Nm

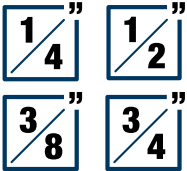

YouTube



692 J32

U06920042

**32
PIECES**



**Assortment with bits and
reversible ratchet - 1/4"**

692 J49

U06920041

**49
PIECES**



Assortment with bits - 1/4"

692 J100

U06920043

**100
PIECES**



**Assortment of bits with special
shapes - 1/4"**

COMBINATION WRENCH 285 J



7
PIECES

8÷19 mm

285 J/DS7
U02851745

- Set of 7 combination wrenches**
- 285 J/8-10-12-13-14-17-19 mm.
 - Supplied with plastic holder



12
PIECES

8÷19 mm

285 J/DS12
U02851746

- Set of 12 combination wrenches**
- 285 J/8-9-10-11-12-13-14-15-16-17-19 mm.
 - Supplied with plastic holder



16
PIECES

6÷24 mm

285 J/B16
U02851740

- Set of 16 combination wrenches**
- 285 J/6-7-8-9-10-11-12-13-14-15-16-17-18-19-22-24 mm.
 - Delivered with roll-up bag

285 KB FLAT RATCHET COMBINATION WRENCH



7
PIECES

8÷19 mm

285 KB/DS7
U02856341

- Set of 7 flat ratchet combination wrenches**
- 285 KB/8-10-12-13-14-17-19 mm.
 - Supplied with plastic holder



12
PIECES

8÷19 mm

285 KB/DS12
U02856342

- Set of 12 flat ratchet combination wrenches**
- 285 KB/8-9-10-11-12-13-14-15-16-17-19 mm.
 - Supplied with plastic holder

Non
bestemmiare
adopera USAG
utensili professionali



Do you need support from us?

Go to our website:



usag.it/en/contacts/support



Promotion valid till 31/03/2027 while stocks last.

The images shown in this catalogue are not binding.

Stanley Black & Decker italia S.r.l. reserves the right to change the technical characteristics of its products at any time.



Stanley Black & Decker Italia S.r.l.

Via Volta, 3 - 21020 - Monvalle (VA)

Tel. +39 0332 790 111 - info.mv@usag.it

usag-tools.net

